

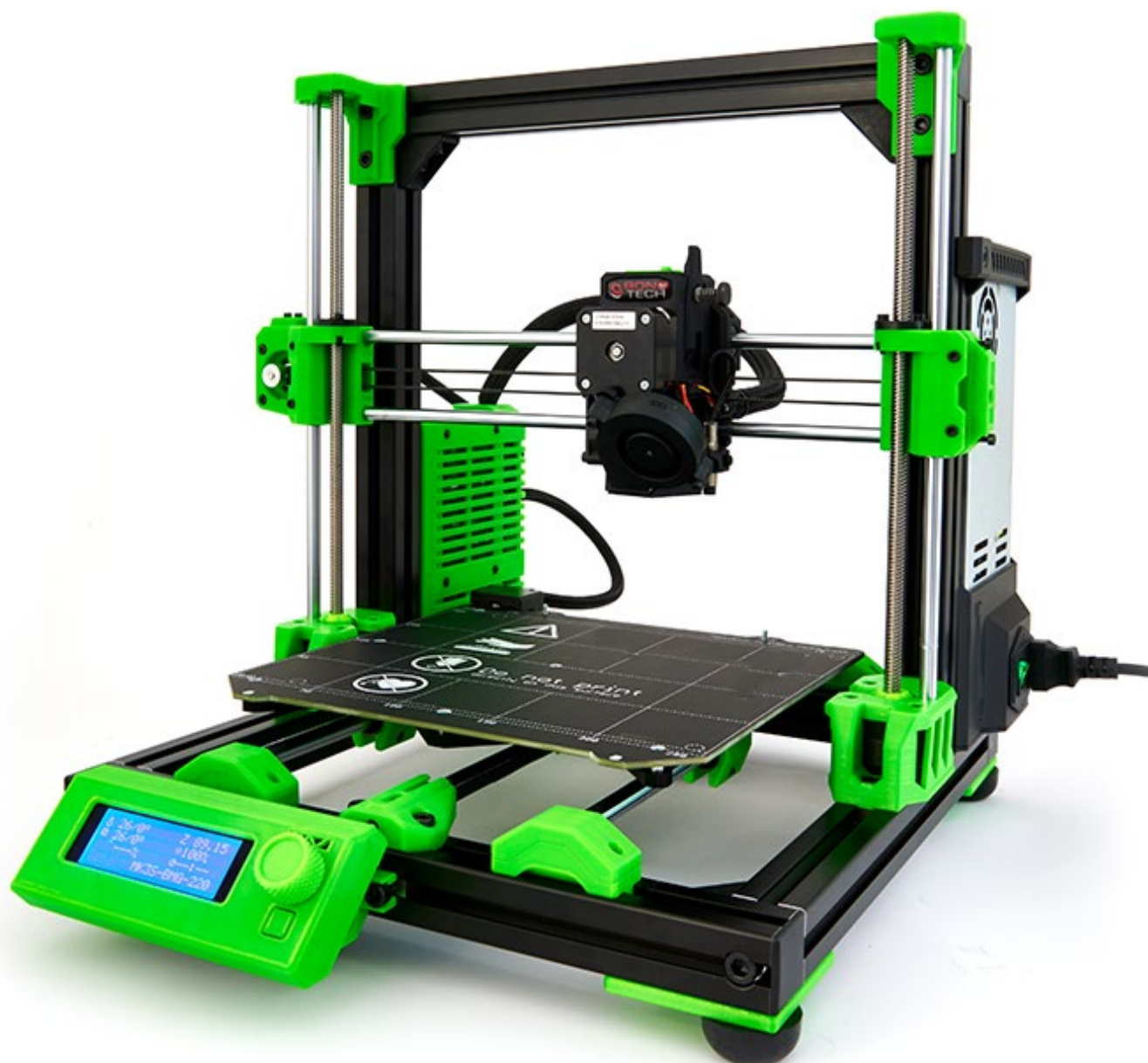

Caribou MK3 Rel. 3

Assembly Manual

Version 1.20
11.09.2020



CARIBOU
Research & Development

DISCLAIMER OF LIABILITY: Caribou3d Research & Development specifically DISCLAIMS LIABILITY FOR INCIDENTAL OR CONSEQUENTIAL DAMAGES and assumes no responsibility or liability for any loss or damage suffered by any person as a result of the use or misuse of any of the provided information or product. Caribou Research & Development assumes or undertakes NO LIABILITY for any loss or damage suffered as a result of the use, misuse or reliance on the information and or product.

USE AT YOUR OWN RISK: Never leave your printer unattended!

© 2020 Caribou3d Research & Development

Authors: Wolfgang Schadow, Ryuichi Shevlin, Henry Schadow, Timon Bald
Photography: Henry Schadow, Wolfgang Schadow, Ryuichi Shevlin (Rel. 2)
Bondtech (Photos in Mosquito sub-section)

1 DISCLAIMER:

This is a kit of components for assembly into a 3D Printer by the end user. Building and using the printer is potentially very dangerous as it involves electricity and high temperatures.

Building the printer will require physical dexterity and a good understanding of what you are doing. We have provided fully comprehensive build documentation to enable you to build your Caribou 3d Printer Kit in a safe manner.

Ultimately, we cannot be responsible for your health and safety while building or operating the printer. With that in mind be sure you are confident with what you are doing prior to buying or building a 3d printer.

Building and operating involves electricity, so all necessary precautions should be taken and adhered to, the printer runs on 110V-220V, supplied by a certified power supply.

High temperatures are involved with 3D Printing, the extruder nozzle runs at 190-285°C. The heated bed runs at up to 110°C and the molten plastic extruded will initially be up to 280°C. Special attention and care should be taken when handling these parts of the printer during operation.

Contents

1	Disclaimer:.....	3
2	Thanks.....	7
2.1	Sources	7
3	General Notice.....	9
4	List of tools.....	10
5	Assembly Instructions	11
5.1	xy-Frame.....	11
5.1.1	Base frame Assembly.....	11
5.1.2	L-Bracket and Feet Installation.....	20
5.2	y-Axis Assembly.....	22
5.2.1	y-Rod Installation	22
5.2.2	Installation of the Heatbed Carriage	25
5.2.3	y-Motor Assembly.....	30
5.2.4	xy-Idler (Tensioner) Assembly	31
5.2.5	y-Idler and y-Belt Installation.....	32
5.3	z-Axis Assembly.....	38
5.4	z-Motors and rods Installation	43
5.5	x-Axis Assembly.....	48
5.5.1	x-MotorHolder Assembly	49
5.5.2	x-Idler Assembly.....	51
5.5.3	Assembling and Installing the x-Axis	52
5.6	z-Top Axis Assembly.....	55
5.6.1	Mounting x-Top-extrusion.....	56
5.7	Heat Bed Installation.....	62
5.8	Einsy Box Assembly	69
5.9	PSU Assembly	73
5.9.1	Preparation of Meanwell RSP-320	73
5.9.2	Preparation of the 250W PSU	78
5.9.3	Installation of the PSU.....	82
6	Extruder Assembly.....	87
6.1	Stock Extruder	87
6.2	Bondtech Extruder.....	87
6.2.1	Mosquito Hotend	87
6.2.2	E3D Hotend Assembly.....	90

6.2.3	Bondtech Extruder Preparation	95
6.2.4	Installing the Fans and the PINDA probe	103
6.2.5	Installation of the Filament Sensor	105
6.2.6	Installing the x-Carriage.....	107
6.3	Extruder Installation	109
6.3.1	Stock Extruder	109
6.3.1	Bondtech Extruder.....	109
6.4	x-Belt installation	116
6.5	LCD Assembly	121
7	Cable routing.....	124
7.1	x-Axis.....	124
7.2	Extruder Cables	127
7.3	LCD cable.....	133
8	Steelsheet and Heatbed Instructions	138
8.1.1	Preparing the Steelsheet	138
8.1.2	Important! Heatbed Instructions	142
9	Setup and Calibration	143
9.1	Flashing Firmware	144
9.2	Self Test	148
9.3	PINDA Adjustment	151
9.4	Nozzle and Hotend Preparation.....	153
9.5	xyz-Calibration.....	157
9.6	Checking the Filament Sensor.....	159
9.7	Loading Filament.....	161
9.8	First Layer Calibration	165
9.9	Final Step: closing the Einsy box	169

APPENDIX

A	Overview of Plastic Parts.....	172
A.1	Frame	172
A.1.1	Einsy	172
A.1.2	Frame Components	173
A.1.3	LCD	173
A.1.4	PSU (Meanwell, Prusa).....	174
A.1.5	Spoolholder.....	176

A.2	Tools	177
A.3	x-Axis.....	178
A.1.6	Bondtech specific parts for x-Axis.....	179
A.1.7	Default Extruder specific parts for x-Axis	180
A.4	y-Axis.....	181
A.5	z-Axis.....	183
A.6	Extruder.....	184
A.1.8	Bondtech Extruder.....	184
A.1.9	Default Extruder.....	186
B	Length of Nylon filament and Techflex Tubes	188
C	EINSY Rambo Conectors.....	189

2 THANKS

There are many people who have contributed on one form or another to the project. We like to thank everybody who inspired or supported us. Many ideas were discussed in the facebook groups:

- Caribou Group: <https://www.facebook.com/groups/caribou3d>
- Caribou Deutsche Gruppe: <https://www.facebook.com/groups/caribou3dde>

Very special thanks to 3d-Gussner and Bernd Brinkert for their huge support and effort in providing and testing Caribou firmware.

Thank you, Rebecca and Jason, from LDO Motors and Martin from Bondtech for the quality manufacturing and relationship.

Thanks to our other supplier: E3d, Microswiss, Slice Engineering, Misumi for delivering high quality products to us.

2.1 SOURCES

We give references that have influenced the design. Since the majority of plastic parts (even if much improved and somehow "new and different") have their roots in the initial design by Prusa Research we like to mention this a first and most influential reference.

- Prusa : <http://www.prusa3d.com>

Frame

- Prusa i3 MK2-X by davtr <https://www.thingiverse.com/thing:1692666>
- Haribo Project https://github.com/PrusaMK2Users/3030_Haribo_Edition

y-rodholder:

- they have been inspired by the design of Piotr Karkovski <https://www.thingiverse.com/thing:2830591>

y-bearing holder

- the clamp mechanism is similar to one used on the x-axis. We like to mention that the first clamp design with insert for the carriage for the bearings holders was done by Vecko Kojchevski <https://www.thingiverse.com/thing:2930007>

x-MotorHolder and X-Idler

- inspired by initial clamp design of Arnaud Rousseau <https://www.thingiverse.com/thing:2964026> hole design seen on some screen shoot of a bear part 😊 Bear x-axis can be found here <https://www.thingiverse.com/thing:3716110>

x-carriage

- earlier carriage design and references therein <https://www.thingiverse.com/thing:2770327>

z-Top Holder

- hole design seen on some screen shoot of a bear part 😊 Bear x-axis can be found here <https://www.thingiverse.com/thing:3716110>

z-Motor Holder

- The new motor holder was designed independently but we would like to point out that a similar design exists by Vecko Kojchevski <https://www.thingiverse.com/thing:2974255>

Meanwell PSU-holder

- Tobias Reischl <https://www.thingiverse.com/thing:3373172>

Extruder of Rel. 2 that still can be used instead of the Bondtech extruder

- MK3 Extruder and X Carriage: Vecko Kojchevski <https://www.thingiverse.com/thing:2843264>

STL for PrusaSlicer as background

- thanks to Patrick Vosshans

Earlier Releases were partly designed by or influenced by:

- Stefan Weber: y-belt tensioner: <https://www.thingiverse.com/thing:2666661>
- Jon Madden: Prusa MK2/S X-Carriage Adjustable Tensioner by: <https://www.thingiverse.com/thing:2770019>
- Vecko Kojchevski: <https://www.thingiverse.com/vekoj/designs>
- Murathan Araz <https://www.thingiverse.com/murathanaraz/designs>
- Ocie Ward

3 GENERAL NOTICE

Before you proceed with any of the construction steps, please do the following:

1. Make sure that the required parts (which are listed at the beginning of each chapter) are all present, correct and not damaged. If that isn't the case, please contact our support (support@caribou3d.com) and we will provide you with a replacement as quickly as possible.
2. Though we remove it for you, check all plastic parts for support material just to be sure.
3. Make sure to have access to all the listed tools. Do not attempt to build without these as the use of incorrect tools may lead to breakage of parts or a faulty construction. If a tool that we use is optional, it will be noted at the corresponding step.
4. Orient all self-securing nuts with the thicker end towards the screw.

4 LIST OF TOOLS

Necessary:

- ball-headed hex keys in sizes 2.5mm, 5mm, 6mm
- hex keys in sizes 1.5mm, 2mm
- ratchet with 5mm and 6mm hex bits
- pliers
- calipers (at least 162mm width)
- wrenches in sizes 7mm, 16mm
- phillips (PH1) and slotted (about 4-6mm wide) screwdriver
- scalpel or cutter knife
- scissors
- permanent marker (thin)
- lighter
- right angle ruler
- IPA (Iso-Propyl-Alcohol) 0.2l
- paper towel
- flat surface

Additionally recommended:

- smooth tongue-and-groove pliers
- cutting pliers
- rubber hammer
- 5.5mm nut driver
- common sense
- latex gloves

5 ASSEMBLY INSTRUCTIONS





5.1 XY-FRAME

5.1.1 BASE FRAME ASSEMBLY



Important: Make sure that the surface that you are working on is perfectly flat. By using an uneven work surface, you risk building a skewed frame, which may lead to the printer not being able to be calibrated.

	<p>Prepare four corner brackets in the following way:</p> <p>Insert a M6 x 12mm screw to one of the holes of the bracket.</p>
	<p>Screw a T-nut on the M6 x 12mm screw. Leave it loose.</p> <p>Top and side view of the bracket.</p> <p>Do the same for the second hole of the bracket.</p>
	<p>Lay out the extrusions so that the x-extrusions are (when viewed from above) horizontal and the y-extrusions vertical. The X- extrusions should be oriented with the larger holes towards the outside.</p> <p>The y-extrusions should have the larger side of the hole facing downwards!</p> <p>Insert two T-nuts into the top facing slot of the Y-extrusion on both sides.</p> <p>Insert a corner bracket into both y-extrusions.</p>
	<p>Slot in the front x-extrusion into the two corner brackets.</p> <p>You don't have to fasten the screws at this point.</p>

	<p>Repeat the last two steps on the back of the frame.</p>
	<p>IMPORTANT: slide in 2x T-nuts in the front slot of the front extrusions. They will be used to attach the LCD.</p>
	<p>Insert the M8 x 40mm screws into the front x-axis.</p>
	<p>Tighten the M8 x 40mm screws slightly.</p>



Now use a right-angle ruler e.g. DIN 875/1 to press the extrusions flat on your build plate while tightening the **M8 x 40mm screw**.

DON'T tighten too much!

Do the same on the left side.

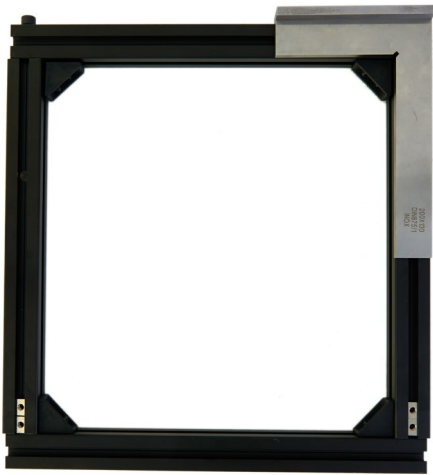

Repeat the last two steps on the back of the frame.



Now when the for **M8 x 40mm** screws are fastened the frame should lay flat on the build plate.

After this, the frame should be perfectly flat and not rock on a flat surface, like a badly made chair might do.



Now fasten the **M6 x 12mm screws** of the corner brackets on y-extrusions.

Don't fasten the screws on the x-extrusions.

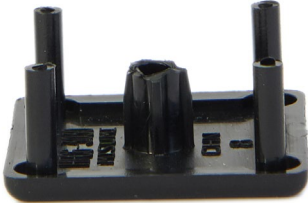
	<p>Now loosen the 4x M8x40mm screws by about 2-3mm. Each corner bracket should now sit flush with the end of the corresponding Y-extrusion.</p>
	<p>Prepare the extrusion covers.</p> <p>The middle part is too long to fit on the end of the extrusions due to clearance issues with the M8x40mm screws. Trim the middle part of the extrusion end caps at about the halfway point.</p> <p>Be careful not to cut them too short, as they may lose their ability to hold onto the end of the extrusion. We recommend using cutting pliers. Trim all four end caps.</p>
	<p>After trimming, they should look like this.</p>



Now install the caps onto the ends of the two X-extrusions.

The thickness of the cap is 2.8mm, which we will use to align the x-extrusions and the corner brackets.



After pushing the caps, the corners of the frame should look like this.

Reminder: Note that at this point the M8x40mm screws are loose.



Top view of a corner.



Using a right-angle ruler to make sure that the two extrusions in one corner are aligned and that the extrusions are at a 90° angle in relation to each other.



Now place the angle on the profiles.





Now tighten the loose **M6x12mm screw** in the corner bracket, fastening the bracket to the x-extrusion. After repeating this for the other 3 corners, check thoroughly that the marked surfaces are indeed correctly aligned.

While holding the frame in place steadily, fully tighten the eight **M6 x 12mm screws** of the corner bracket with a ratchet.

It is incredibly important that the frame doesn't twist while tightening the screws.

The following two steps are OPTIONAL: if you own calipers that are 300m long.

	<p>Measure the distance between the two Y-extrusions at the front. This should be somewhere around 299.40 – 300.00mm.</p>
	<p>Now measure the rear part of the frame. The difference in length in comparison to the front should not exceed 0.1mm. The smaller the difference, the straighter the frame. Write down both measurements when you are done.</p>



Tighten the four M8 x 40mm.

Don't overtighten them. This may bend the frame.



Remove one of the end caps on the front and on the back of the frame

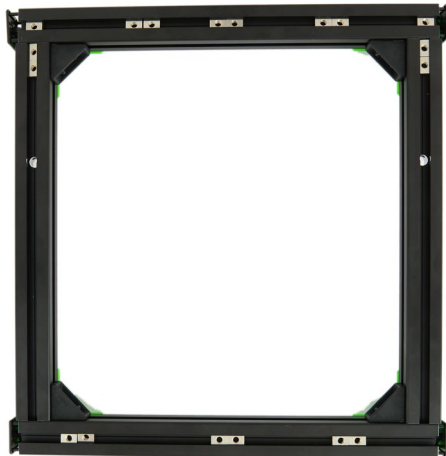

Insert **6x T-nuts** in upper slot of the front extrusion.

Insert **8x T-nuts** in the upper slot of the rear extrusion.

Now the top of your frame should look like this.

Insert the two end caps back to the frame

5.1.2 L-BRACKET AND FEET INSTALLATION

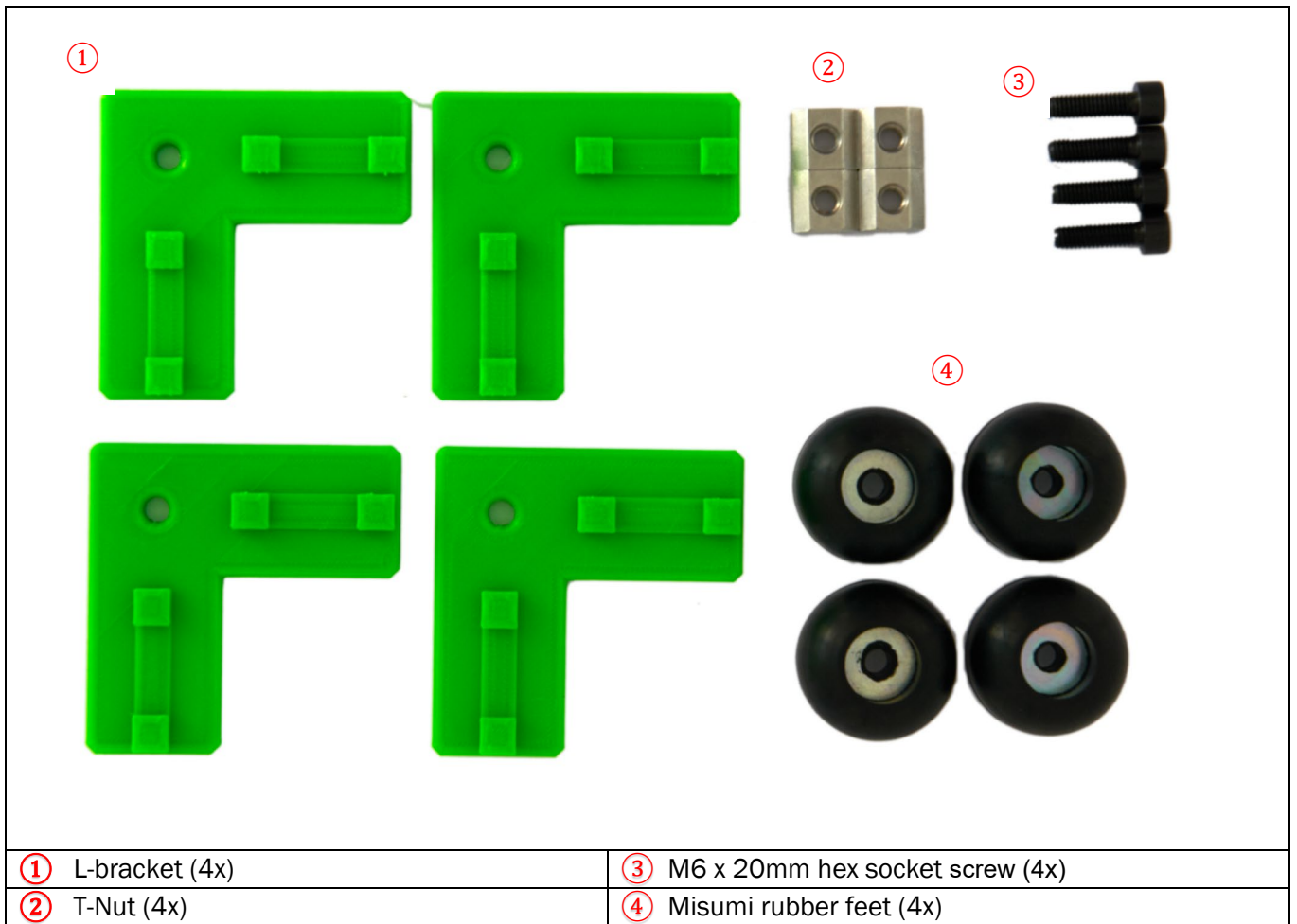



Flip the frame upside down.



Insert **2x T-nuts** into the (now) upper slots of each extrusion.



For each corner, set a T-nut in the position as seen in the picture, and place an L-bracket over it.





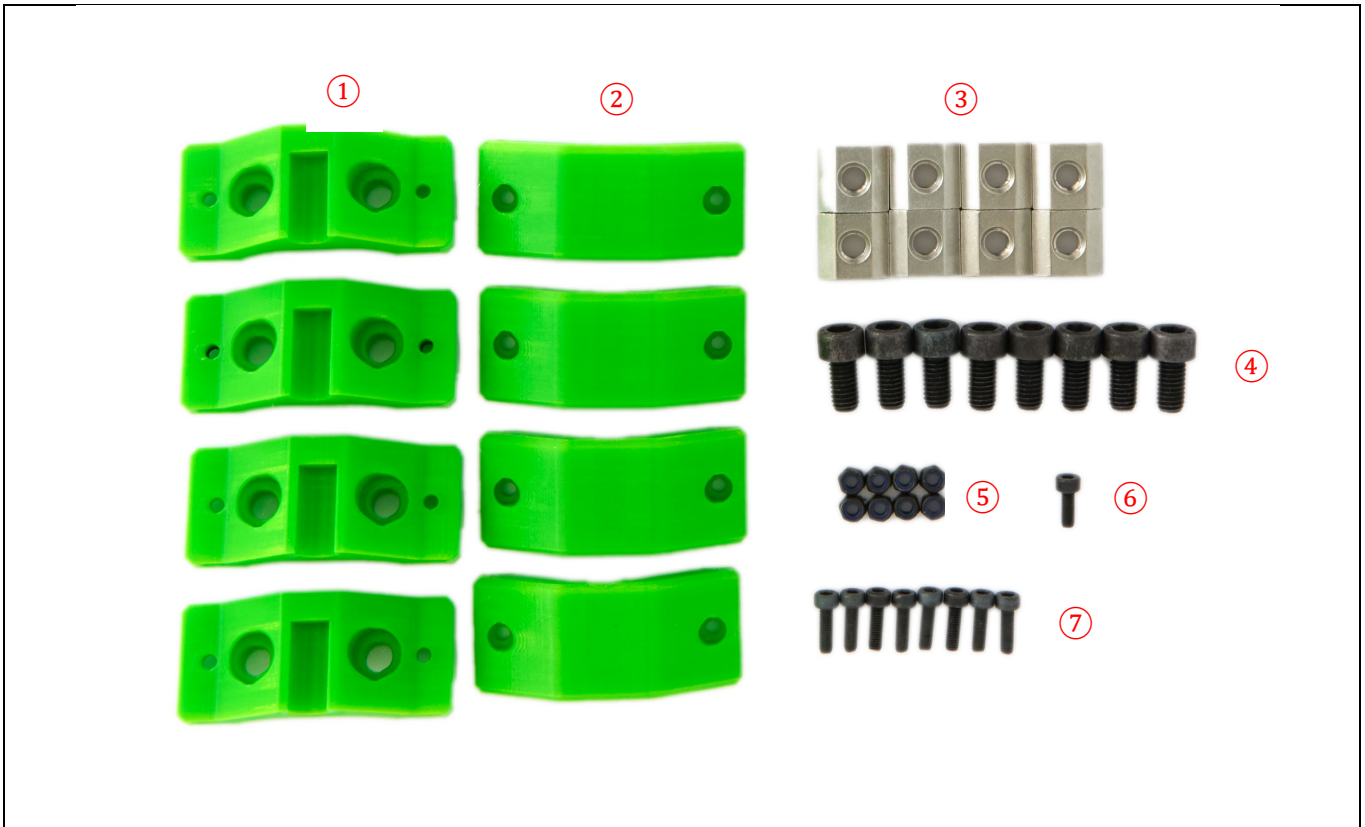

For each corner, place one of the rubber feet onto the bracket. Use a **M6x20mm** screw to secure it and the L-bracket into place.

5.2 Y-AXIS ASSEMBLY

5.2.1 Y-ROD INSTALLATION

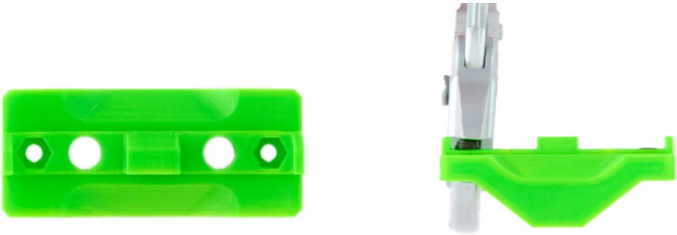

① y-rod mount (4x)	⑤ M3 hex nut (8x)
② y-rod mount cover (4x)	⑥ M3 x 8mm hex socket screw (1x)
③ T-Nut (8x)	⑦ M3 x 10mm hex socket screw (8x)
④ M6 x 12mm hex socket screw (8x)	

	<p>Insert 2x M3 self-securing hex nuts into each Y-rod mount bottom. You may use pliers to do so.</p>
	<p>Using an M3x8mm screw, pull the nuts into their slots.</p>
	<p>Set the frame to be in the following position. Position the T-nuts in the extrusion as shown in the picture.</p>
	<p>Place a rod mount onto the frame, with each of the holes dedicated to a T-nut.</p> <p>Repeat the same for the opposite side.</p> <p>Now clip in a 360mm rod as seen in the picture.</p>



Use the y-alignment tool to make the rod parallel to the y-extrusions.

Do this by firstly placing the tool at the top and then pushing the rod against it. Secondly slide the tool down the frame to the other side and push the rod against it again. Do this a few times just to be sure that the rod is straight.

Secure the mounts in place using the marked holes, using two **M6x12mm screws**.







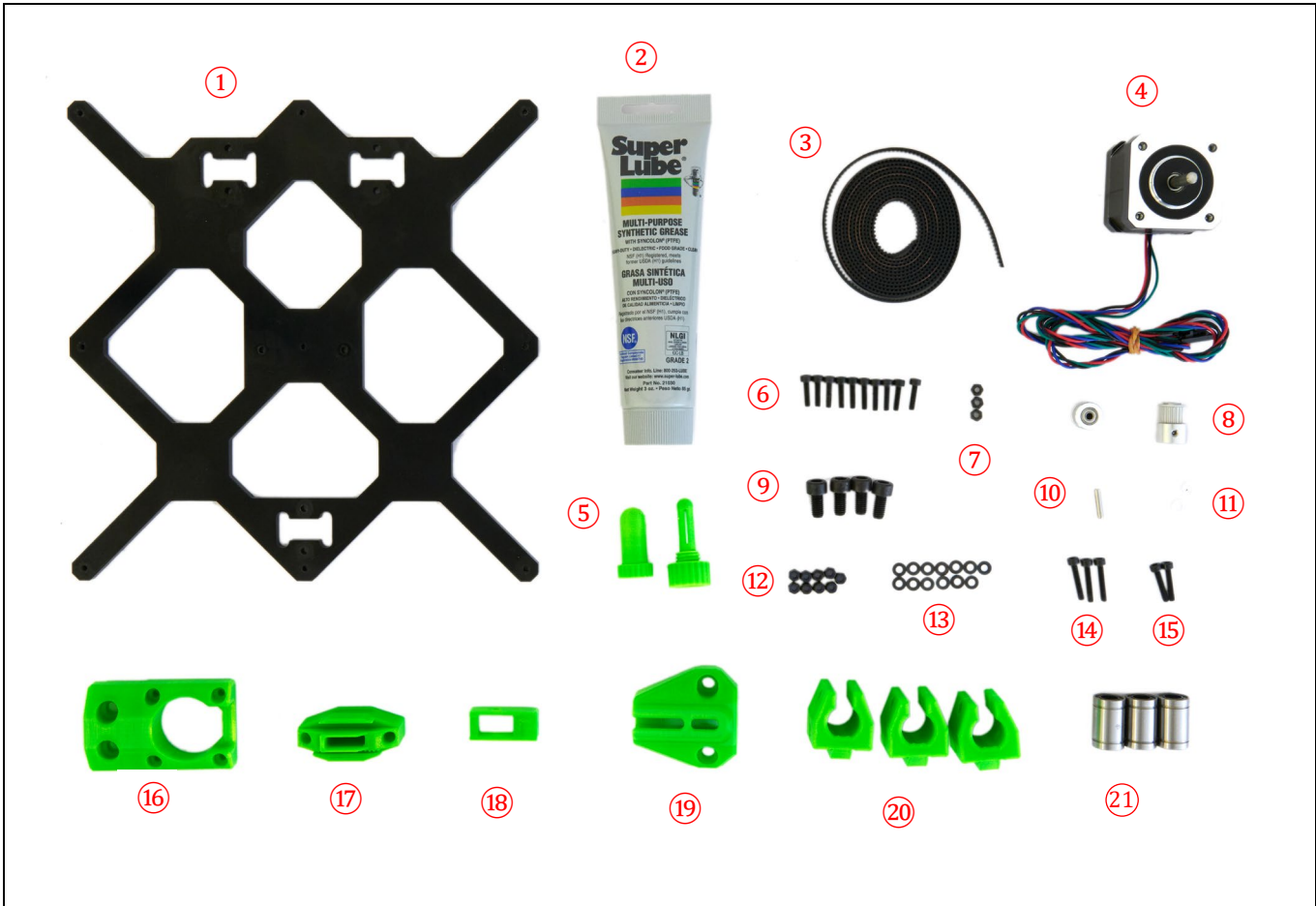

Prepare the other **360mm rod** for installation. We will adjust its position later when we fix it in place.

5.2.2 INSTALLATION OF THE HEATBED CARRIAGE

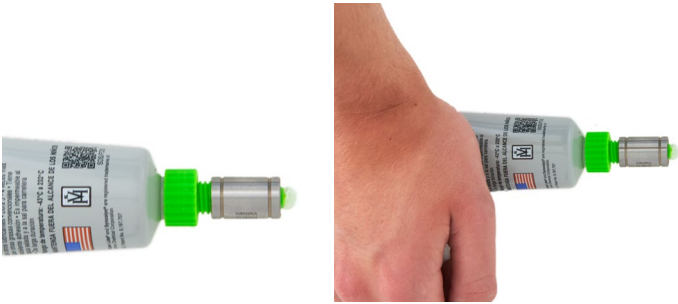

① Y-carriage	⑫ M3 nyloc nuts (9x)
② Superlube	⑬ M3 washer (13x)
③ GT3 Belt	⑭ M3 x 18mm screw (3x)
④ y-Motor	⑮ M3 x 16mm screw (2x)
⑤ Grease injector + cap	⑯ y-MotorHolder
⑥ M3 x 12mm screw (10x)	⑰ y-BeltHolder
⑦ M3 hex nut	⑱ xy-BeltTensioner insert
⑧ toothless pulley + GT3 toothed pulley	⑲ y-BeltTensioner
⑨ M6 x 12mm screw (4x)	⑳ Y-BearingHolder (3x)
⑩ Dowel pin	㉑ LMU8 Bearings (3x)
⑪ Plastic washer (2x) (invisible)	

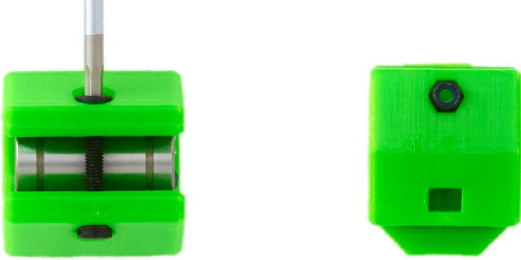
	<p>Immerse the 10 supplied bearings for about 20min in IPA.</p> <p>Take them out and let them dry for about 10-15min on a paper towel.</p>
	<p>Open the super lube tube and screw on the provided injector.</p>
	<p>Place a bearing on the injector and align the channels of the bearing with the slots on the injector. Press the grease into the bearing. You are done when grease comes out the end.</p> <p>If you want to save time, do this for every bearing in the kit so that you won't have to do it again later.</p>
	<p>Insert the bearing into the bearing mount. Make sure that once inserted, the channels of the bearing form an "X". (a "+" with a 45° offset)</p>

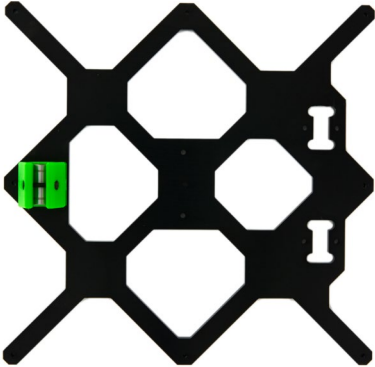
	<p>Pay attention to the orientation of the bearings. The balls should be oriented in a 45° angle with respect to the top plane of the holder.</p>
	<p>Secure the bearing by pushing in a M3 hex nut on one side and screwing in a M3 x 18mm screw.</p> <p>Do not over tighten this screw, as you will risk breaking the bearing mount. It is only meant to stop the bearing from falling out.</p>
	<p>Insert 2x M3 self-securing nuts on each side of the bearing holder. Check for alignment with the hole in the top of the bearing mount.</p>
	<p>Mount the bearings holders to the y-carriage and fasten them with 2x M3 washer and 2x M3 x 12mm screws.</p>

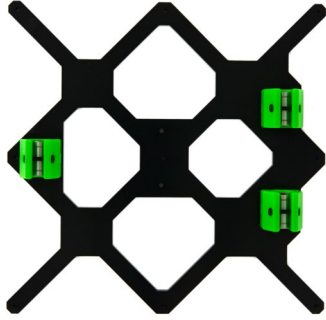

Don't fasten the bearing holders yet. The holders should be able to move and rotate slightly.



View from the side.



View from top.



Carefully lift the installed y-rods and slide in the carriage.

Pay attention to the direction. When viewed from **behind** the side with the two bearings has to be on the right.

Slide the carriage back and forth so that the left (loose) rod can align.

Now fasten the **M6 x 12mm screws** of the y-rodholders.

Make sure the carriage can slide easily.



You can also measure the distance between the two rods. It should measure 162mm (160mm for 10mm version).

Slide the carriage back and forth and start fastening the screws of the bearing holders.



Don't fasten them in one go. Fasten each screw by half a turn and move on to the next.

Keep sliding the carriage back and forth to ensure it's moving freely.

Once all six screws are fastened the carriage should run smoothly on the rods.

If not loosen all six screws and start over.

5.2.3 Y-MOTOR ASSEMBLY



Attach the motor mount onto the motor, with the cables exiting towards the M6 holes on the back (don't get confused by the picture). Use **4x M3 washers** and **M3x10mm screws** to attach the motor to the mount.



Slide the toothed GT3 pulley onto the motor shaft. The pulley has two fastening screws, make sure one of them is aligned with the flat surface of the shaft.

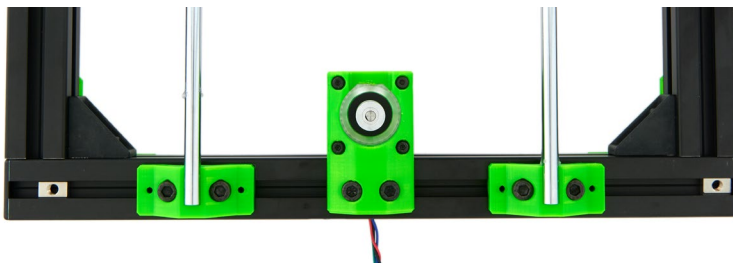

The end of the shaft should sit flush with the flat side of the pulley.





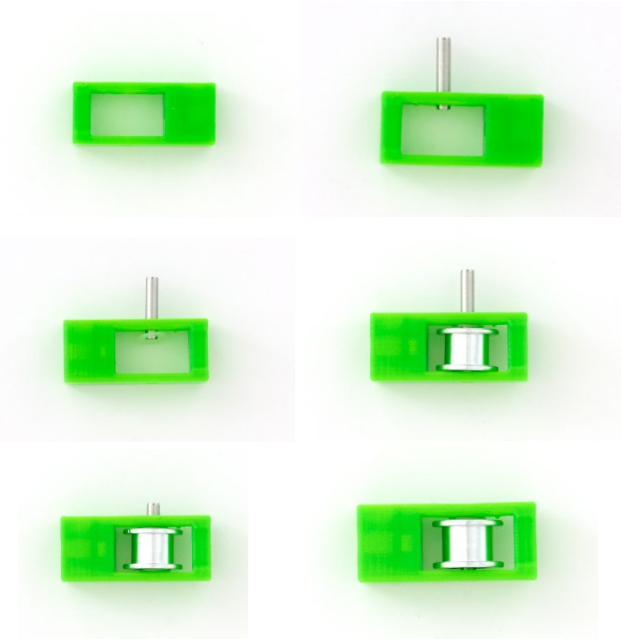

Now attach the motor assembly to the rear extrusion, with the motor on the inner side of the frame. Use two **M6x12mm screws** and the **2x T-nuts** that we inserted into the extrusion in chapter 1.

Leave these lightly loose as we will adjust the position of the motor along the extrusion later.

5.2.4 XY-IDLER (TENSIONER) ASSEMBLY

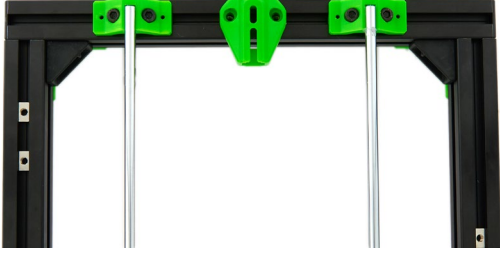
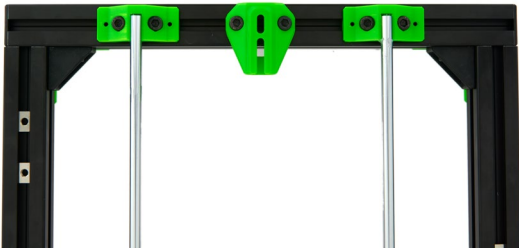
	<p>Take the belt tensioner and insert the dowel pin until you can see about half a millimeter of the pin inside the tensioner. If you feel that the hole is too small, you may use a 3mm drill bit (by hand!) to widen the hole slightly.</p> <p>Place a plastic washer on the dowel pin and insert the toothless pulley. Push the dowel further until it reaches the end of the pulley.</p> <p>Insert the second plastic washer and push the dowel pin all the way through the tensioner insert.</p> <p>Handle the part with care as brute force may cause it to break.</p>
	<p>Finally insert a self-locking nut into the slot of the tensioner.</p> <p>Prepare a second one for the x-axis.</p>

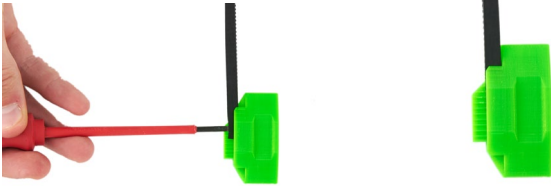
5.2.5 Y-IDLER AND Y-BELT INSTALLATION

	<p>Attach the Y-belt tensioner mount to the front extrusion opposite to the motor in the orientation shown.</p>
	<p>Use two M6 x 12mm screws and the 2x T-nuts that we inserted into the extrusion in chapter 1.</p> <p>Leave these lightly loose as we will adjust the position of the y-belt tensioner mount along the extrusion later.</p>
	<p>Cut the provided GT3 belt in two pieces of about 1m. The two pieces are for the axes x and z respectively.</p> <p>Using half of the available teeth, insert the belt into the slot.</p>
	<p>You may use a large slot screwdriver to gently push the belt in.</p>
	<p>Insert 2x M3 x 16mm screws into their designated holes.</p>



Pay attention to the orientation of the belt holder. The side with the fastened belt should face the side of the carriage with ONE bearing.

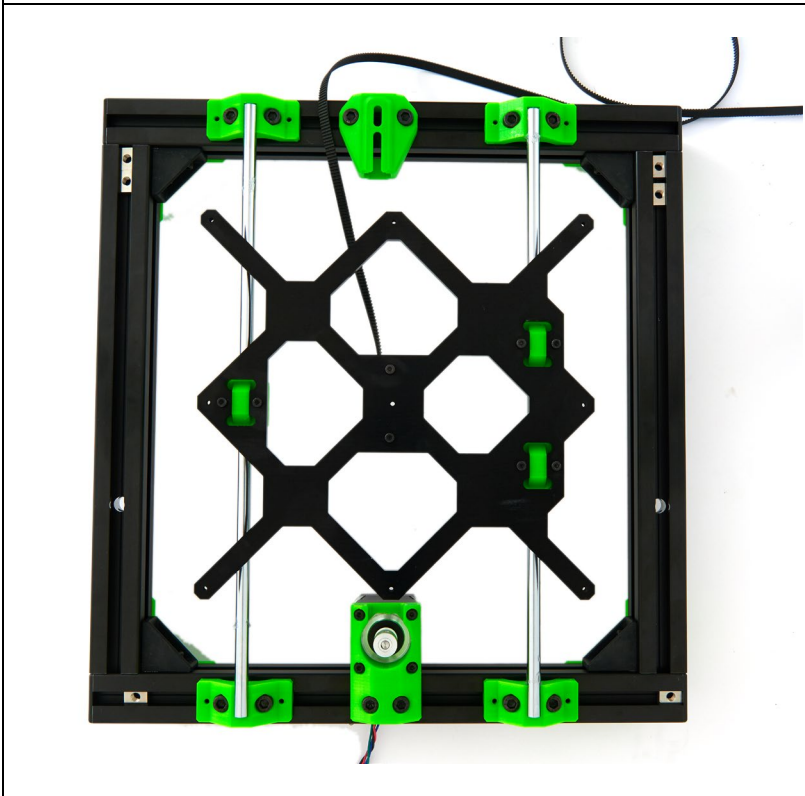

Take two **M3 washers** and **2x M3 self-locking nuts** to fasten the belt holder to the bottom of the carriage.



Loop the belt around the tensioner pulley.

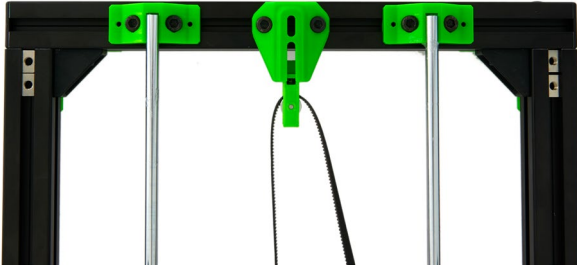

Insert the tensioner into the housing with the nut facing upwards.

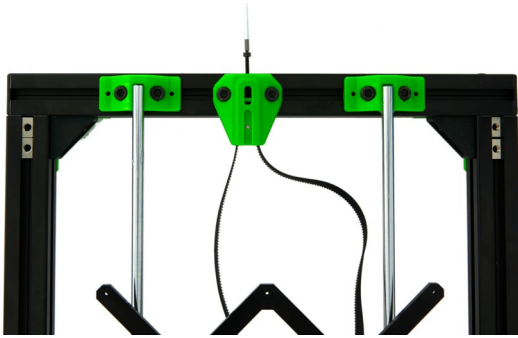

Push an **M3x18mm screw** into the housing and screw it in till it reaches the tensioner.



View from below

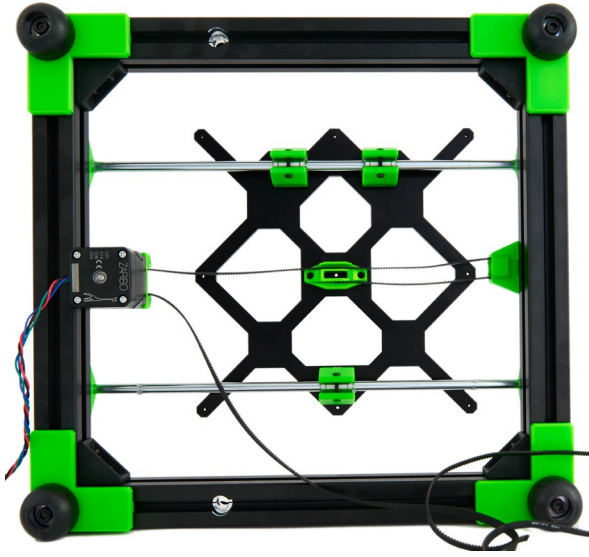

Now loop the belt around the motor.

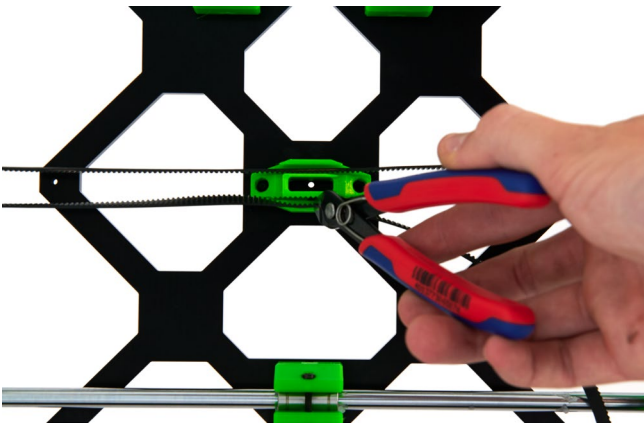

Hold the belt against the belt mount to see how much of the belt you must trim. Cut off the excess.

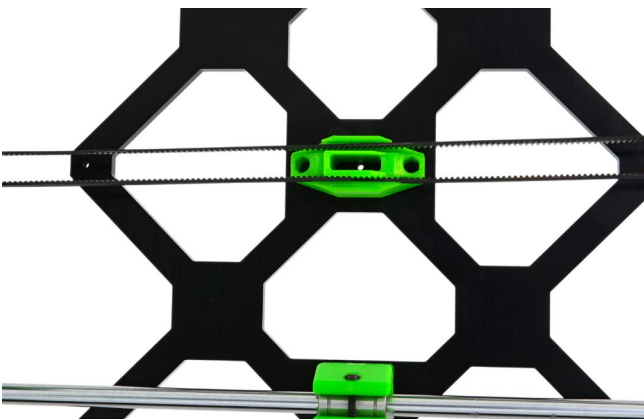

Insert the belt into the mount.

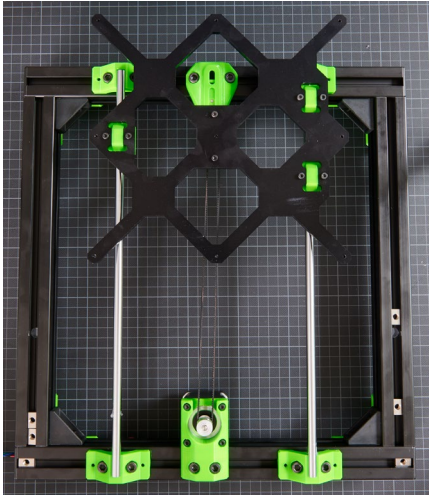

This is an example of a badly aligned belt.

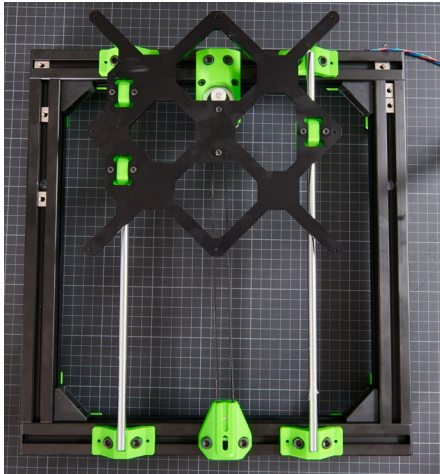

Using a working mat with a grid can be very helpful for you to determine whether the belt is aligned correctly.

Move the carriage to the back. Make sure that the screws that attach to the belt mount are in one line with the motor shaft.

Secure the motor to the frame by tightening the **2x M6 x 12mm screws**.

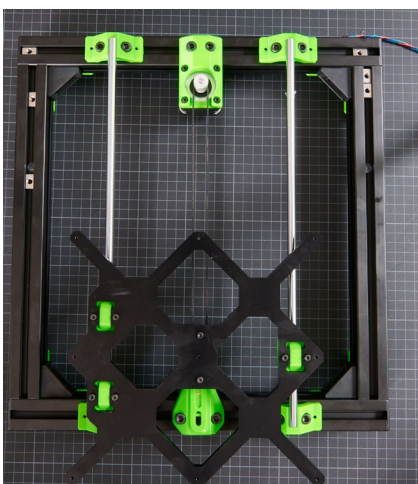

Move the carriage to the front and position the tensioner so that the dowel pin and the two screws line up. Then offset the tensioner to the left by 0.8mm.

This is to compensate for the lack of teeth on the tensioner pulley which results in a greater diameter (1.6mm larger).

Tighten the M6 screws.

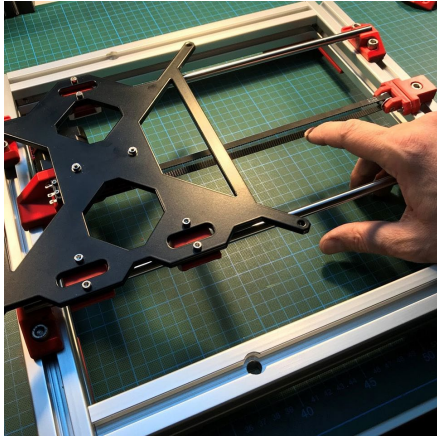

Make sure the belt tension has a frequency of around **70 Hz**. To measure the frequency, you can either use a frequency counter or an app e.g. EasyTension.

Follow this procedure to adjust:

- Move the bed all the way to the motor side
- Now use the frequency meter of the Easy tension app to measure the frequency of the lower belt (not connected to the bed)
- Adjust the belt tension



Place the rod mount covers onto the rod mounts.



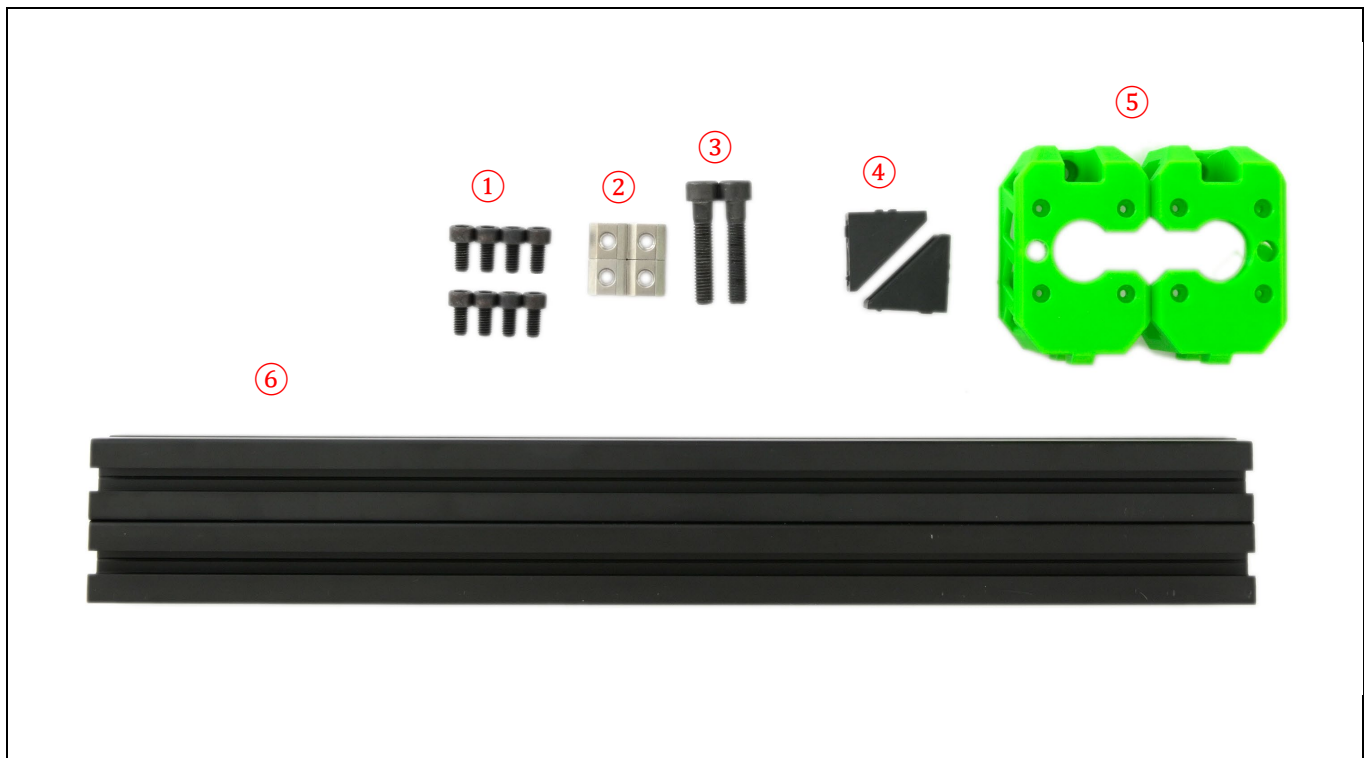

Screw them down with **2x M3x10mm screws** each. Do not push the screw in as you risk pushing the nut out the other end. Instead, screw the screw in.

5.3 Z-AXIS ASSEMBLY

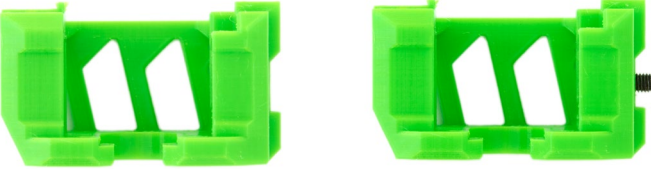
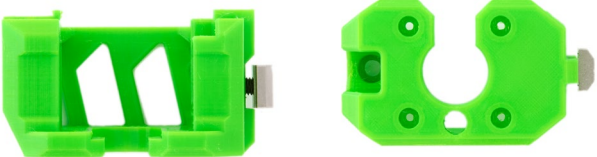

① M3 x 12mm screw (8x)	④ Corner bracket (2x)
② T-Nut (4x)	⑤ z-motor mount, left and right
③ M8 x 40mm screw (2x)	⑥ z-Extrusions (320mm for Caribou 220, 420mm for Caribou 320, 520mm for Caribou 420)

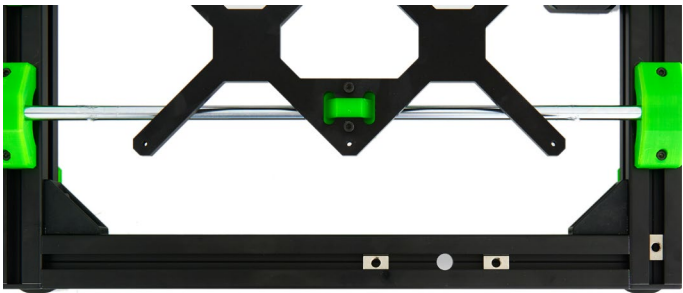
	<p>NOTE: you must prepare both z-motor mounts like this.</p> <p>Insert a M6 x 12mm screw into the back of the holder.</p>
	<p>Screw a T-nut on the M6 x 12mm screw.</p> <p>The right holder will look like this. Repeat the same preparation for the left z-motor holder.</p>
	<p>Prepare two corner brackets in the following way:</p> <p>Insert a M6 x 12mm screw to one of the holes of the bracket.</p>
	<p>Screw a T-nut on the M6 x 12mm screw.</p> <p>Top and side view of the bracket.</p>
	<p>Now continue with the xy-frame that was assembled so far.</p> <p>Make sure one of the T-nuts is in front side of the hole for the z-axis and one is on the back side!</p>



Place the z-Extrusions over the hole and fasten from below with a **M8 x 40mm screw**.

Only tighten loosely!!



Slide the right z-motor holder and a corner bracket into the extrusion slot (T-nut goes into the slot).

Push both to the bottom of the extrusion so that they sit on the xy-frame.



Make sure the corner bracket and the motor holder sit flush in the xy-frame and fasten the **M6 x 12mm screws** that are attached to the T-nuts.



Make sure the T-nuts in the xy-frame sit under the hole of the motor holder and under the corner bracket.

Take **2x M6 x 12mm screws** and screw them into the motor holder and the T-nut below. Do the same for the corner bracket.

Don't tighten the screws yet. You should still be able to move the y-extrusion back and forth by about 1mm.



Now comes another important step in order to get a square frame. It needs to be ensured that that both z-axis have the same distance to the back.

Use the z-alignment tool and slide it into the x-extrusions on the back. Press the z-extrusion to the back so that it touches the alignment tool.

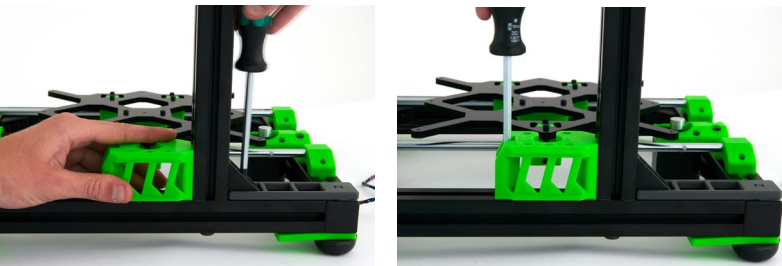

Fasten the corner bracket with a **M6 x 12mm screw**.

Fasten the front side of the motor with a **M6 x 12mm screw**.

Make sure the z-extrusion side flush with y-extrusion on the side.

Fasten the **M8 x 40mm screws** of the z-extrusions.

Repeat the above steps for the other side of the frame.

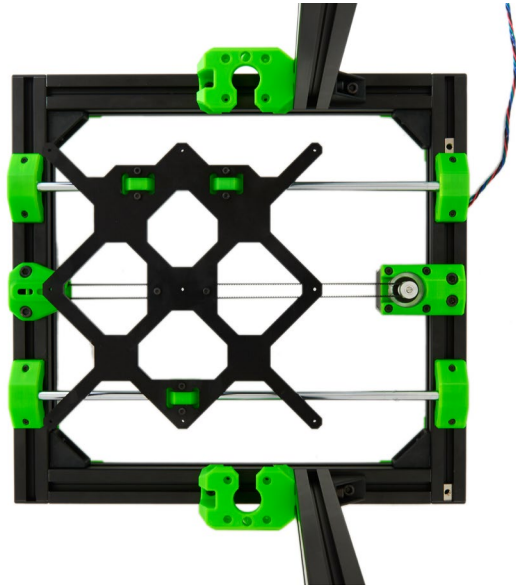

After completing the motor and z-axis assembly your frame should look like this.

In the last step the two z-motors are attached.

5.4 Z-MOTORS AND RODS INSTALLATION

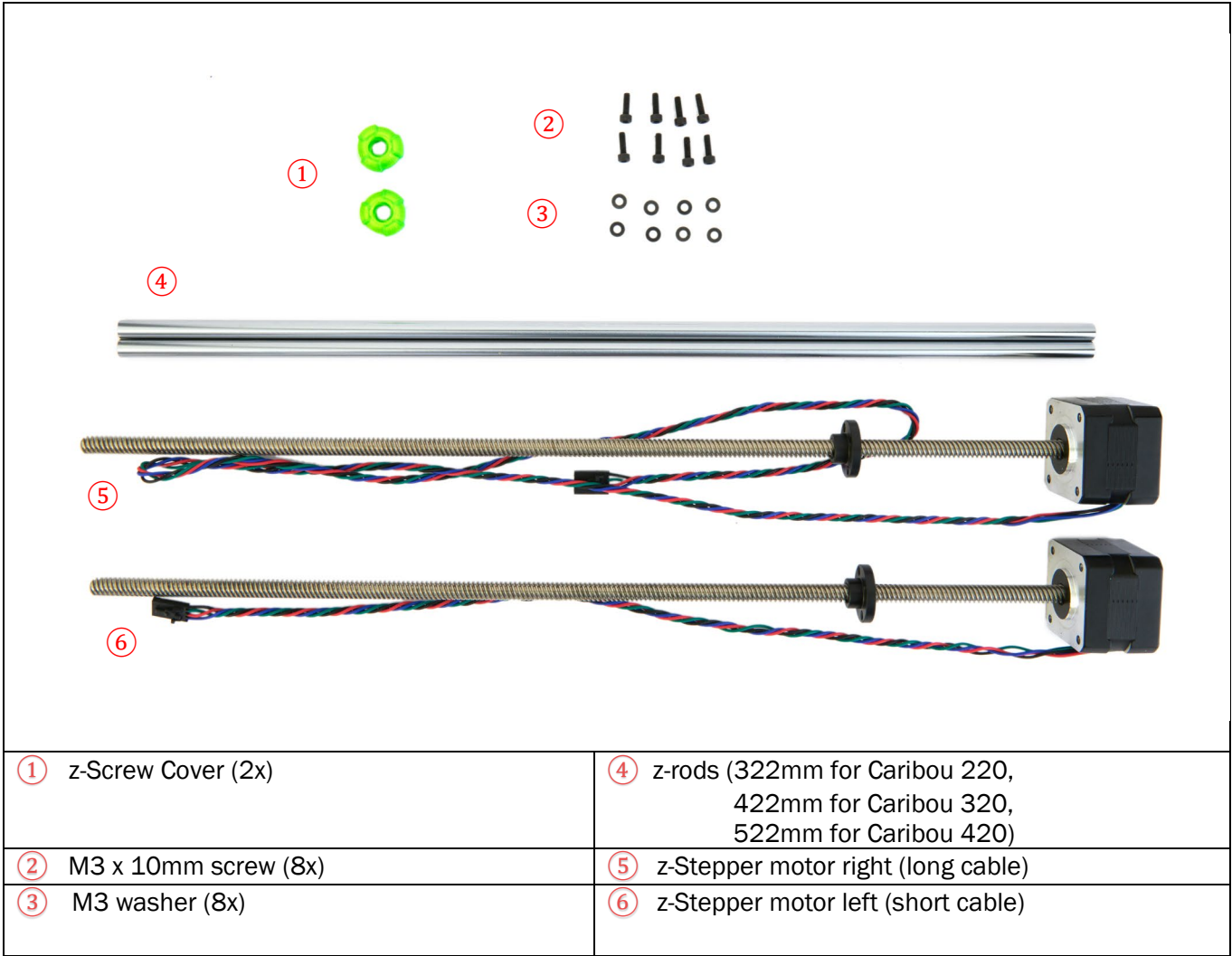



Start with the z-motor with the longer cable for the right side of the printer.

Unscrew the POM nut We'll need that for assembly of the x-axis.



Place the motor next to the bottom of the motor holder on the right side. The cable should be oriented backwards.

Gently slide the motor into the holder. Make sure the cables don't get squashed.



Push the motor fully inside.

Make sure you can press them against the top of the holder and that cables can go under the motor.

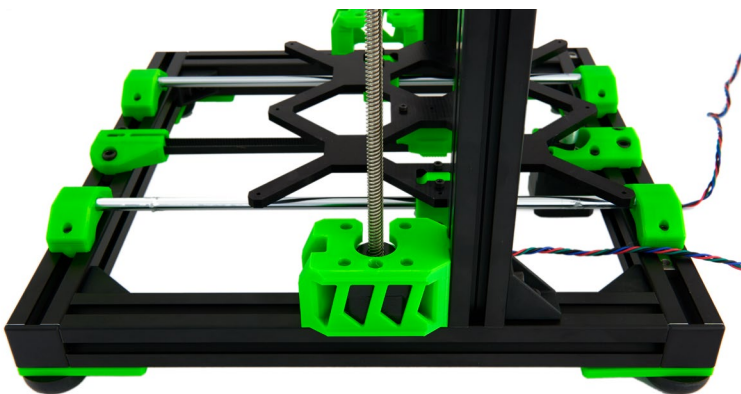

Put **4x-M3 washers**, one in each hole.

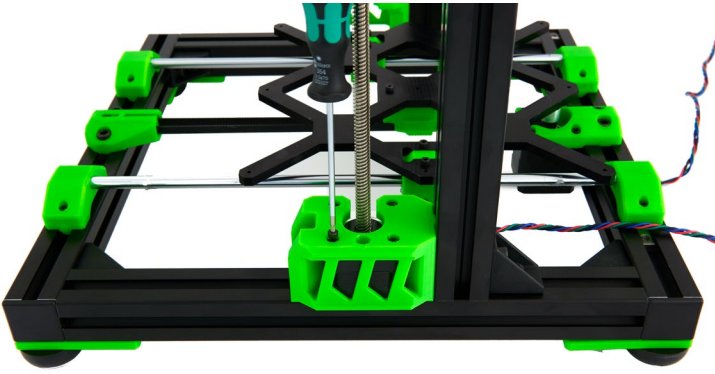

Use **M3 x 10mm screws** to fasten the motor to the holder. Don't fasten them fully yet.

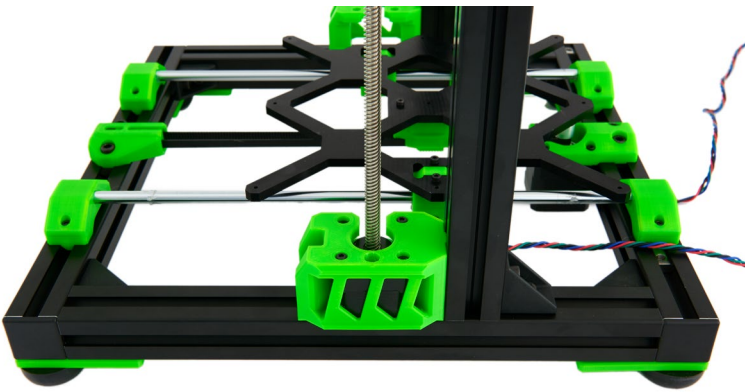

After the first screw fasten the screw on the diagonal hole.

Then do the same for the other two holes.

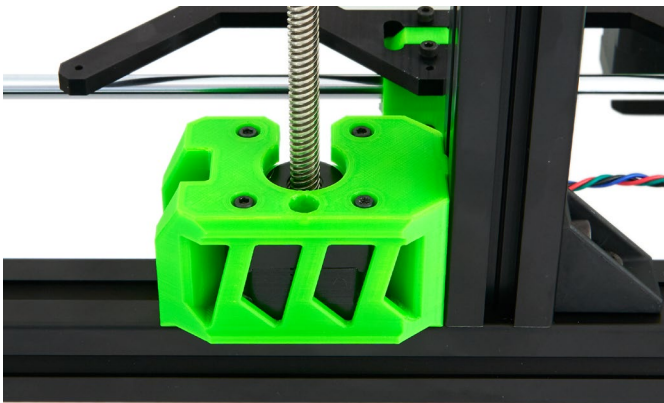

When all four screws are half way in start fastening them more and more. Make sure that the motor is upright in the holder and parallel to the z-extrusion

Repeat the same with the motor on the left side.



You may use a flexible hammer to GENTLY hammer the rods into the motor holder. Make to have to rods straight upright.



On both z-motors install the z-screw covers.



Screw them all the way down.



Don't tight them!



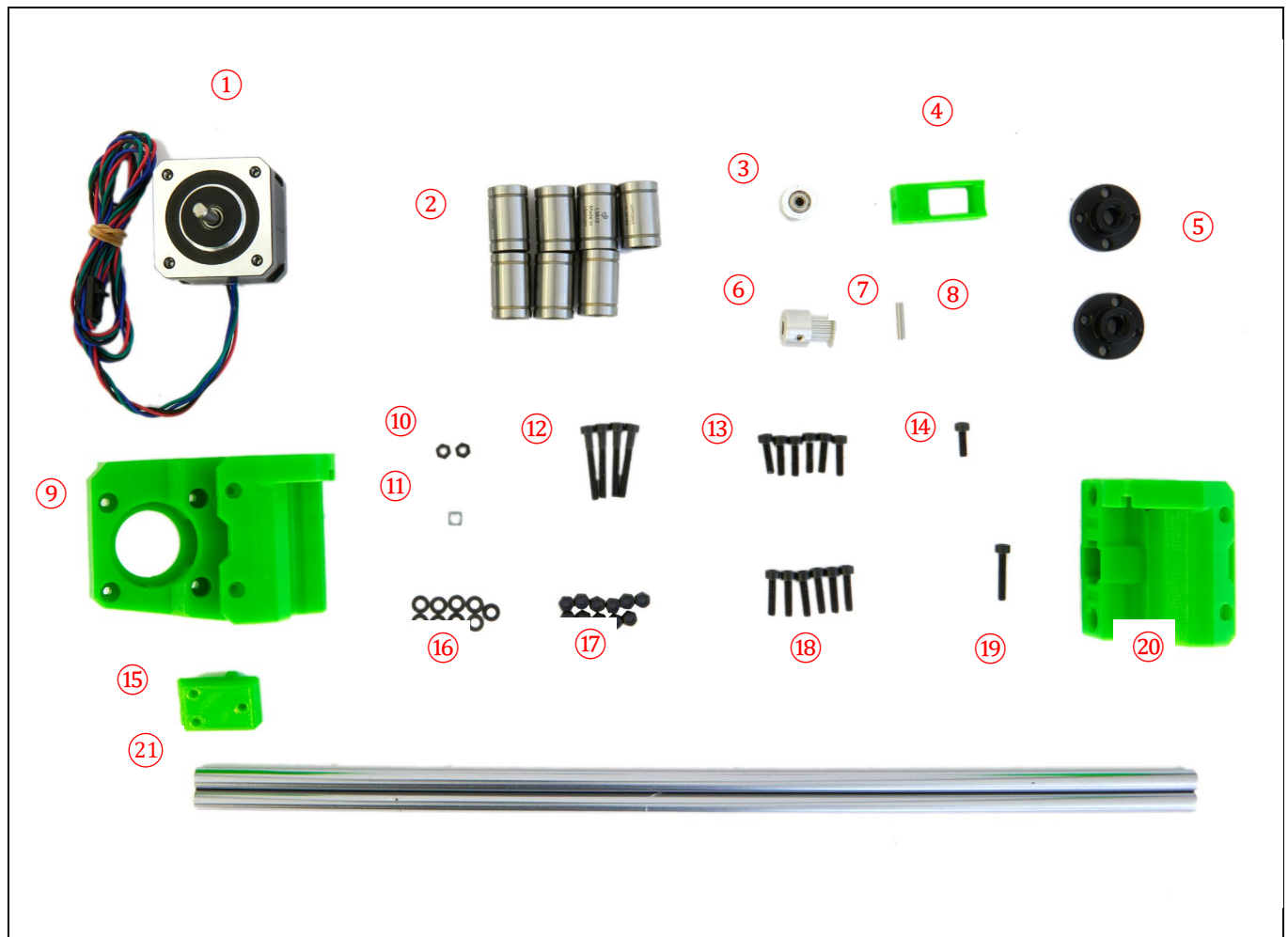

Leave about 1mm between screw and top of the motor. Make sure the lead screw of the motor can rotate freely!



5.5 X-AXIS ASSEMBLY

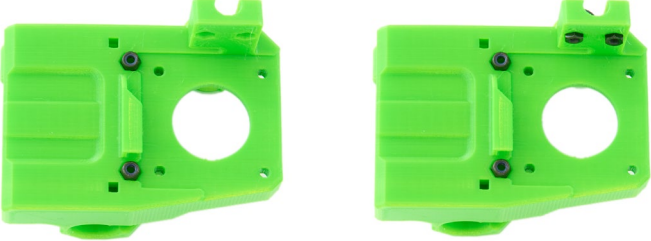

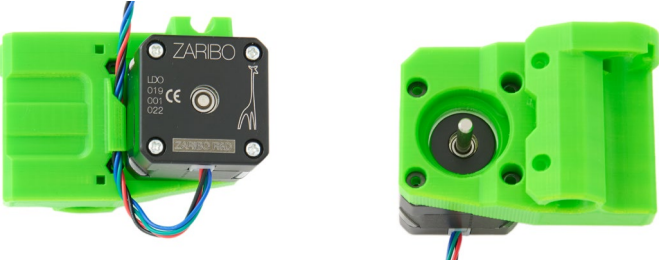

① Stepper Motor	⑫ M3 x 25mm screw (4x)
② Bearings 10mm (7x)	⑬ M3 x 12mm screw (6x)
③ Toothless pulley	⑭ M3 x 10mm
④ xy BeltTensioner	⑮ x-MotorHolderCover
⑤ POM nuts (2x)	⑯ M3 nyloc nuts (11x)
⑥ GT3 toothed pulley	⑰ M3 x 14mm screw (6x)
⑦ Dowel pin	⑱ M3 x 18mm screw
⑧ Plastic washer (2x) invisible	⑲ y-BeltTensioner
⑨ x-MotorHolder	⑳ x-idler
⑩ M3 hex nuts	㉑ x-rods 370mm (2x)
⑪ M3 square nut	

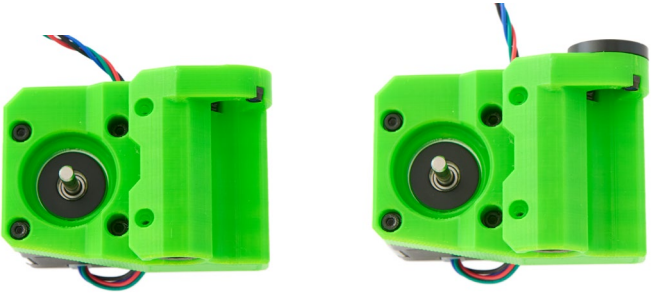
5.5.1 X-MOTORHOLDER ASSEMBLY

	<p>Insert 2x M3 self securing nuts on the back of the x-MotorHolder.</p> <p>Insert 2x M3 hex nuts at the top for the motor holder cover.</p>
	<p>Use a screwdriver to push in the self-securing nuts.</p> <p>Use a plier to push in the hex nuts. As an alternative use a M3 x 10mm head cap screw to pull in the hex nuts into the holder.</p>
	<p>Place one stepper motor on the back of the holder and make sure that the cables runs through the cable holder</p> <p>Turn the motor holder around and insert M3 washers into the hole of the screws for the motor.</p>
	<p>Fasten the motor with 4x M3 x 12mm head cap screws.</p> <p>Insert one bearing from the top and one from the bottom into the holder. Make sure to push them far enough so that they touch the stop in the middle in the holder.</p>

	<p>Insert 2x M3 self-securing nuts into the slots close the hole for the POM nut.</p> <p>Insert the POM nut.</p>
	<p>Take 2x M3 washers and 2x M3 x 14mm head cap screws to fasten the POM. Don't tighten the screws yet. This will be done in a later step.</p> <p>Use 2x M3 x 25mm head cap screws (for 10mm version use 2x M3 x 30mm) to fasten the bearings. Only tighten the screws until you feel that the screws grab on the self-securing nuts. Don't overtighten!</p>
	<p>Slide the toothed GT3 pulley onto the motor shaft. The pulley has two fastening screws, make sure one of them is aligned with the flat surface of the shaft.</p> <p>Leave a thin gap between the pulley and the motor face, as to avoid rubbing.</p> <p>The two pictures show the assembled motor holder.</p>

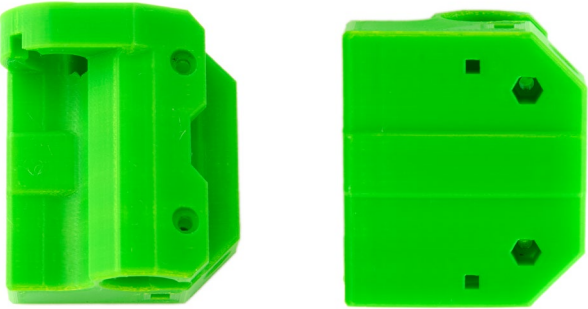
5.5.2 X-IDLER ASSEMBLY

	<p>Follow the same steps for the x-idler as for the x-motor holder:</p> <ul style="list-style-type: none"> - Insert 2x M3 self-securing nuts on the back of the x-MotorHolder - Insert 2x self-securing nuts into the slots close the hole for the POM nut - Insert the POM nut - Take 2x M3 washers and 2x M3 x 14mm head cap screws to fasten the POM. Don't tighten the screws yet. This will be done in a later step - Use 2x M3 x 25mm head cap screws (for 10mm version use 2x M3 x 30mm) to fasten the bearings. Only tighten the screws until you feel that the screws grab on the self-securing nuts. Don't overtighten!
	<p>Insert 1x M3 self-securing nut at the top and one at the bottom of the idler</p>
	<p>View from the bottom of the assembled x-idler.</p>

5.5.3 ASSEMBLING AND INSTALLING THE X-AXIS

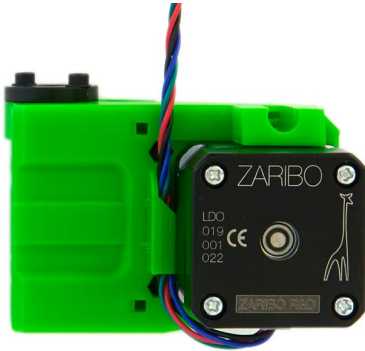

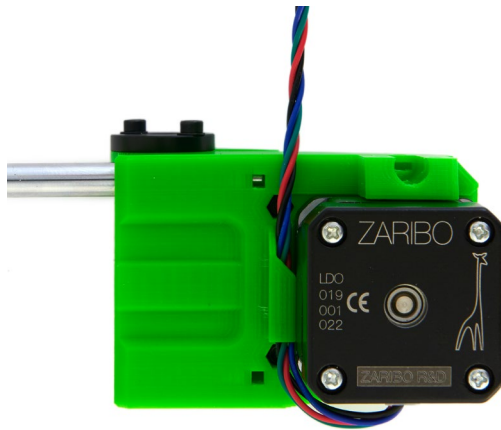

Start with the motor holder. Make sure the cable is routed correctly.

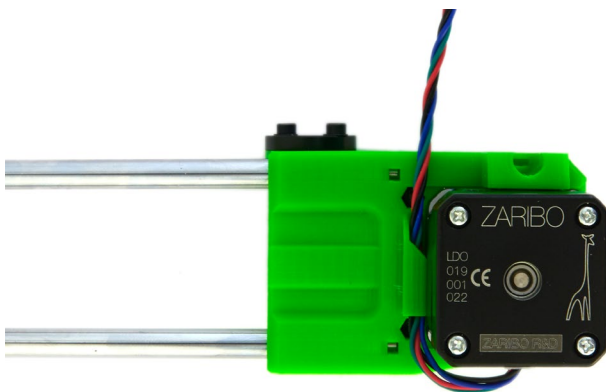

Push a x-rod (370mm) into the upper hole. Make sure it's pushed all the way in by checking through the little window. You must be able to see the rod pushed in all the way.

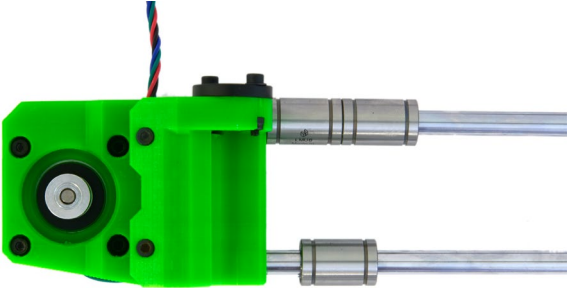

Do the same with the rod at the bottom.

	<p>Insert the bearing on the rods. Two bearing go on the upper rod.</p> <p>Insert one bearing on the lower rod.</p>
	<p>Slide them all the way to motor. Make once again sure the you have inserted the correct number on each rod.</p>
	<p>Now slide the rods into the idler. The idler has the little windows on the back for verification.</p> <p>Just in case you may set the motor side on the ground and gently use a hammer to push the idler in.</p>
	<p>Make sure rods and lead screws are parallel.</p>

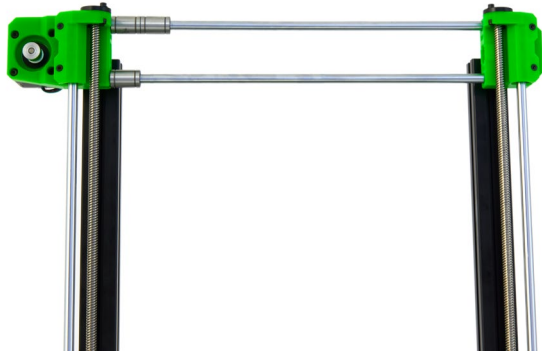

Carefully insert the x-axis onto the z-rods. Pay attention that the rods smoothly slide into the bearings.

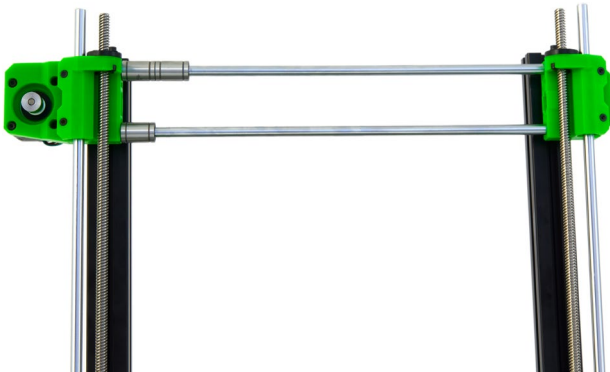

Once the lead screws reach the POM make sure both sides are roughly on the same height.

By turning the z-motors simultaneously you can now screw the lead screws into the POM nuts.

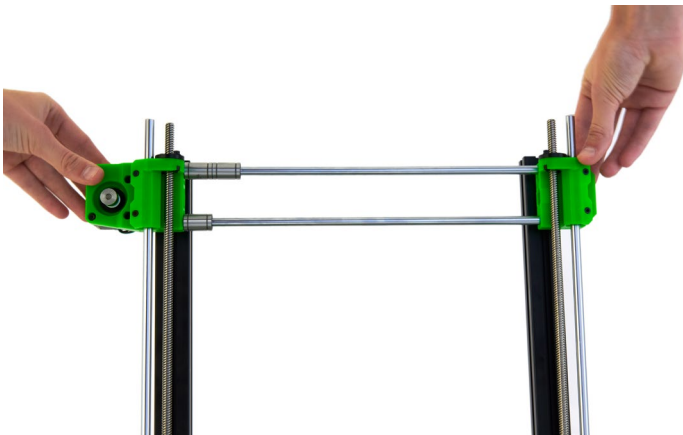

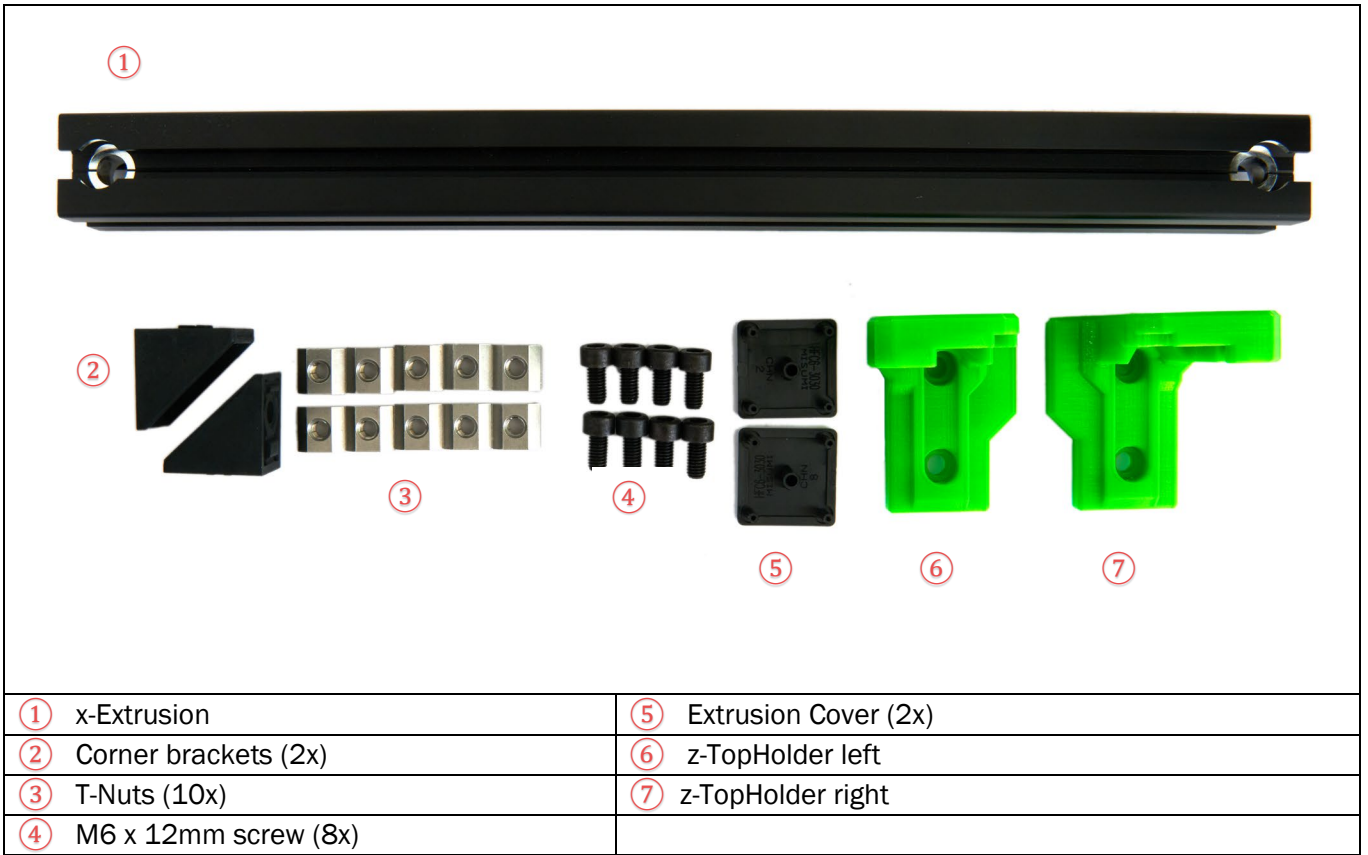

You should now be able to push the x-axis down on the z-axis. Just a few centimeters are enough.

5.6 Z-TOP AXIS ASSEMBLY

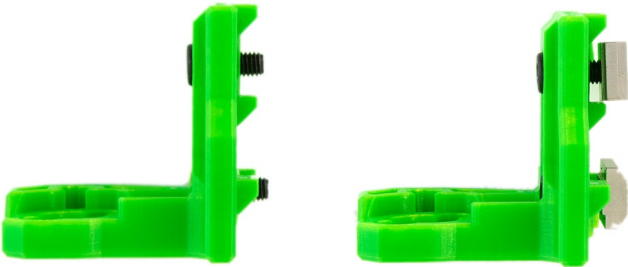

5.6.1 MOUNTING X-TOP-EXTRUSION

	<p>Prepare two corner brackets in the following way:</p> <p>Insert a M6 x 12mm screw to one of the holes of the bracket.</p>
	<p>Screw a T-nut on the M6 x 12mm screw.</p> <p>Top and side view of the bracket.</p> <p>Do the same for the second hole of the bracket.</p>
	<p>Put the two corner brackets onto the x-extrusion, in the slot with the two smaller screw holes.</p>
	<p>Prepare the left and right z-top holder by putting in 2x M6 x 12mm screws from the front and screwing in 2 T-nuts from the back.</p>



Put the x-extrusion onto the printer as seen in the picture, with the **T-nuts** of the corner brackets properly slotted into the inner slots of the z-extrusions.

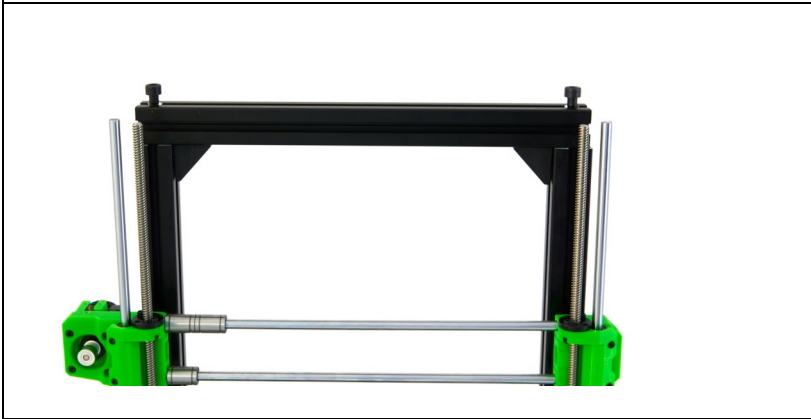

Screw in both **M8x40mm screws** into the top, and tighten them slightly.



While pushing the corner brackets up against the x-extrusion, screw in the horizontal **M6x12mm screws**.
Do this for both sides of the frame.



Remove both **M8x40mm screws** in order to be able to slide the extrusion.



Slide the x-extrusion to the right.

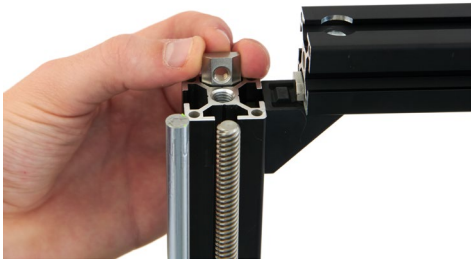

Insert **1x T-nut** into the back slot of the left z-extrusion. (needed to the Einsy box)



Install the left top bracket, making sure the notch is properly inserted in the z-extrusion.



You may use a hammer to VERY GENTLY place the top mount onto the rod.

Please pay attention to the next picture!

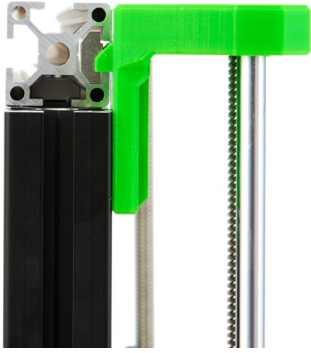

Gently adjust the height of the top bracket so that its upper notch is aligned with the extrusion slot of the X-extrusion.

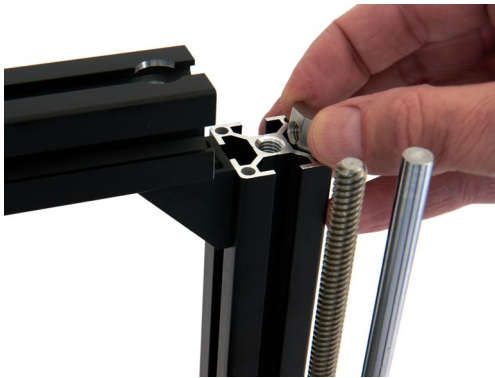

Now continue on the right side of the printer. Slide the x-extrusion a bit to the left.

Insert one t-nut into the right extrusion slot (for PSU top holder)



Now attach the top holder in the same way as on the left side.



Insert **1x T-nut** into the top slot of the x-extrusion for the spool holder.



Prepare the extrusion covers.

The middle part is too long to fit on the end of the extrusions due to clearance issues with the M8x40mm screws. Trim the middle part of the extrusion end caps at about the halfway point.

Be careful not to cut them too short, as they may lose their ability to hold onto the end of the extrusion. We recommend using cutting pliers. Trim all four end caps.



After trimming, they should look like this.



Insert the slot cover on the x-axis.

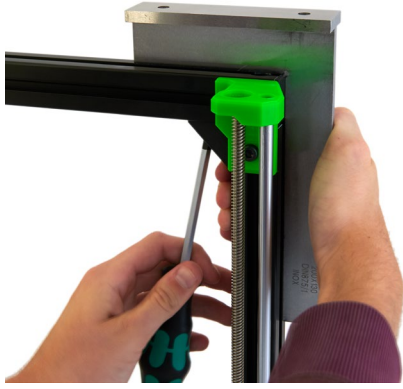

Use a right-angle tool to make sure there is a 90° angle between the x- and the z-axis.

Fasten the **M6 x 12mm screw** of the corner bracket,

Do the same on the left side.



Now fasten the **2x M8 x 40mm screws** at the top. Don't fasten too tight!



Fasten the **2x M6 x 12mm screws** on each top holder.

5.7 HEAT BED INSTALLATION



① Heat bed	⑤ M3 hex nut (2x)
② Distance holders 6mm (9x)	⑥ M3 x 12mm countersunk screw (3x)
③ M3 x 12mm countersunk screw (9x)	⑦ Heat bed cover top
④ M3 nyloc nut	⑧ Heat bed cover bottom

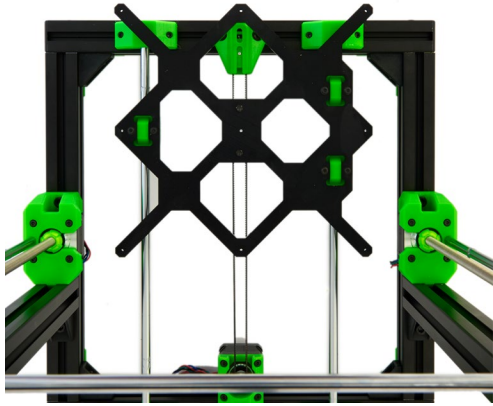

Pull the heat bed carriage to the front of the frame.

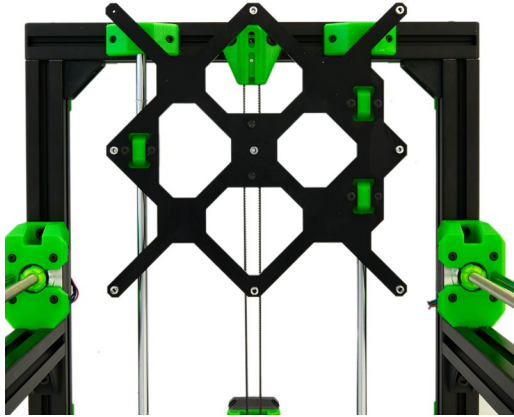

Place a spacer over each of the 9 threaded holes for the heat bed.

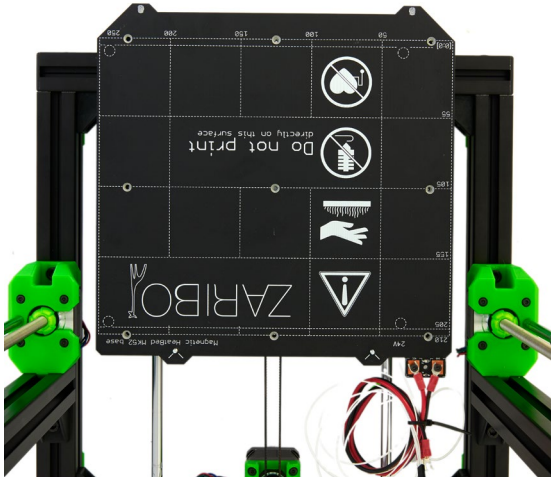

Carefully place the heat bed onto the spacers and check that the holes are aligned with the spacers

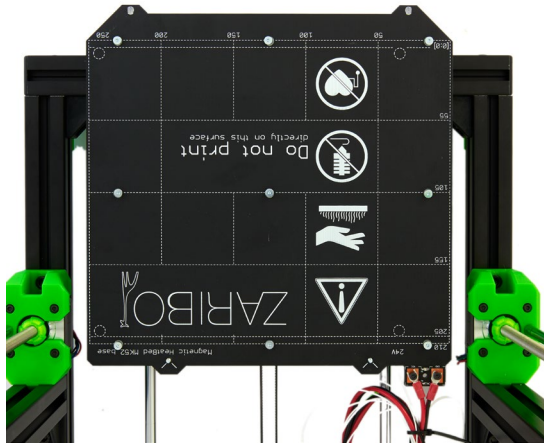

Screw the bed to the carriage using the **9x M3x12mm countersunk screws**.

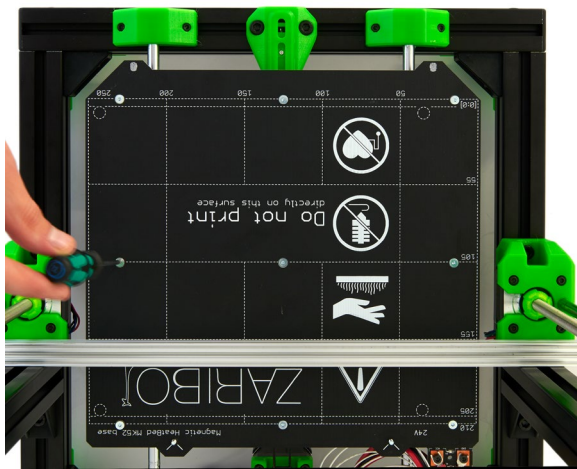

Use a long object you trust to be straight and push it against the front of the z-extrusions. Check if the chosen object is perfectly aligned with the lines on the heat bed.

If it isn't, loosen the nine screws, and tighten them again while you hold the heat bed straight.



For extra precision use the screw holes, as the printed lines might not be 100% correct.

If you fail to get it aligned, take the bed off and realign the y-carriage by redoing the **6x M3x16mm screws** of the y-carriage.



Prepare the heat bed cover top by inserting to **M3 hex nut** into the holes on the back.

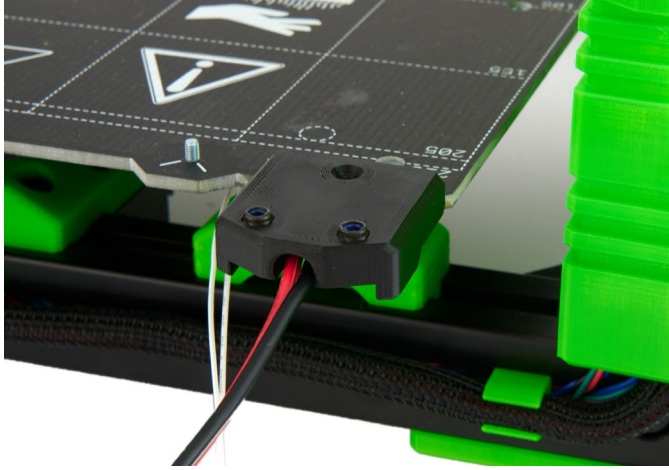

Place the top part of the cover on the heat bed. Align it with the screw hole in the bed.

(Ignore Einsky box in the picture!)

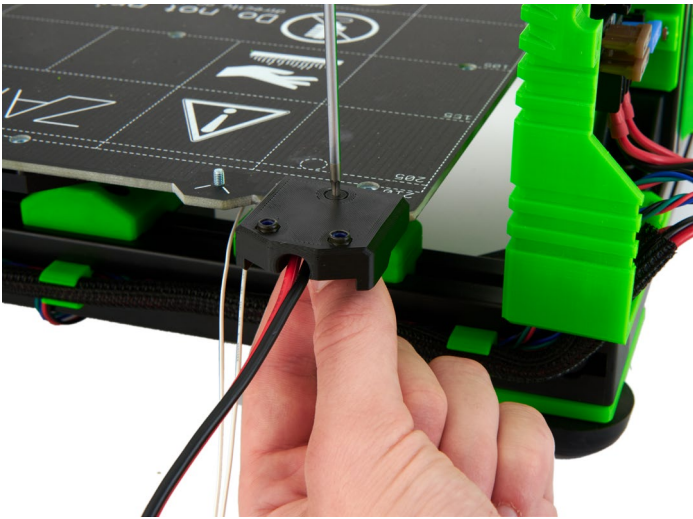

Place the head bed cover top on the contacts as seen in the picture and push through an **M3x12mm countersunk screw** through the hole and secure it with a nut from the other side.

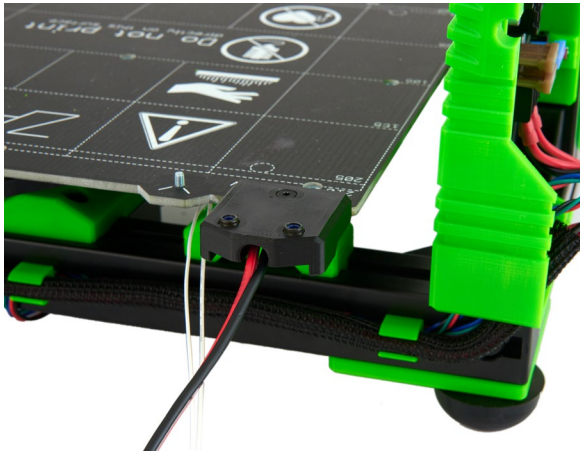

Fasten the screw gently and don't overtighten.

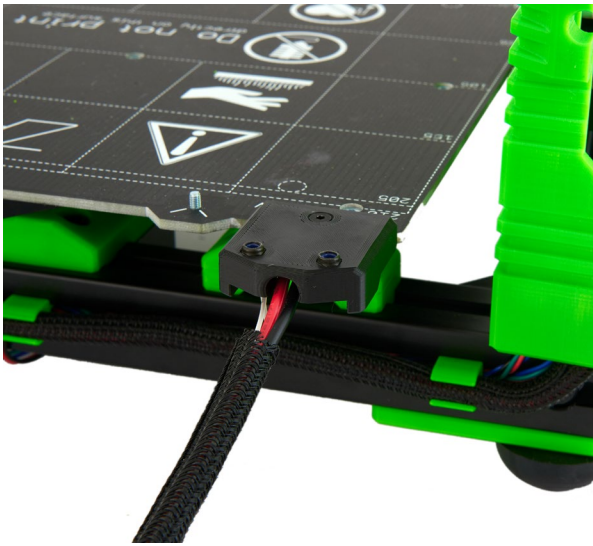

Cut off a 32 cm piece of the provided 6.4mm Techflex tube. Heat up both ends shortly with a lighter.

Slide the heat bed cables and the thermistor cables inside the tube.



Cut a 34 cm piece of the nylon filament. Slide into the Techflex tube.

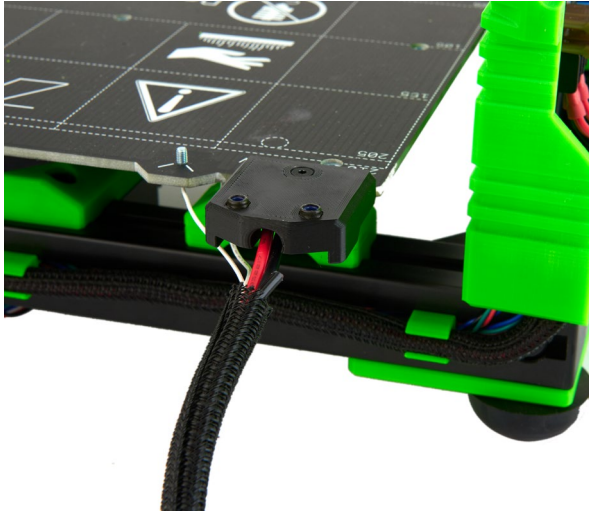

Make sure about 1cm of the nylon filament is standing out at the end.

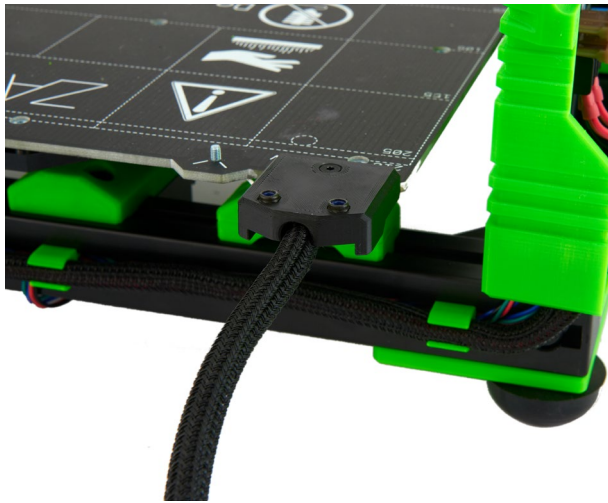

Slide the Techflex tube and nylon filament under the cover.

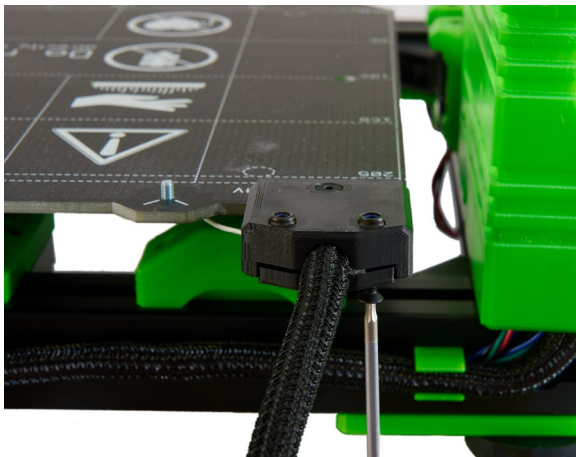

Fasten the lower part of the cover with **2x M3 x 12mm countersunk screws**

Start on one side a fasten the screw halfway. The insert the second screw halfway. Finally fasten both screws.

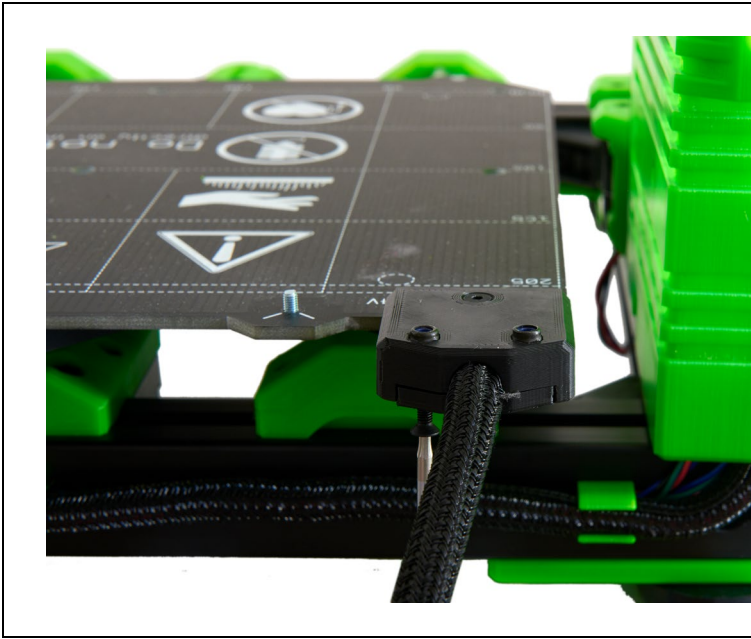

Final look of the heat bed cover and cable with sleeve.

5.8 EINSY BOX ASSEMBLY

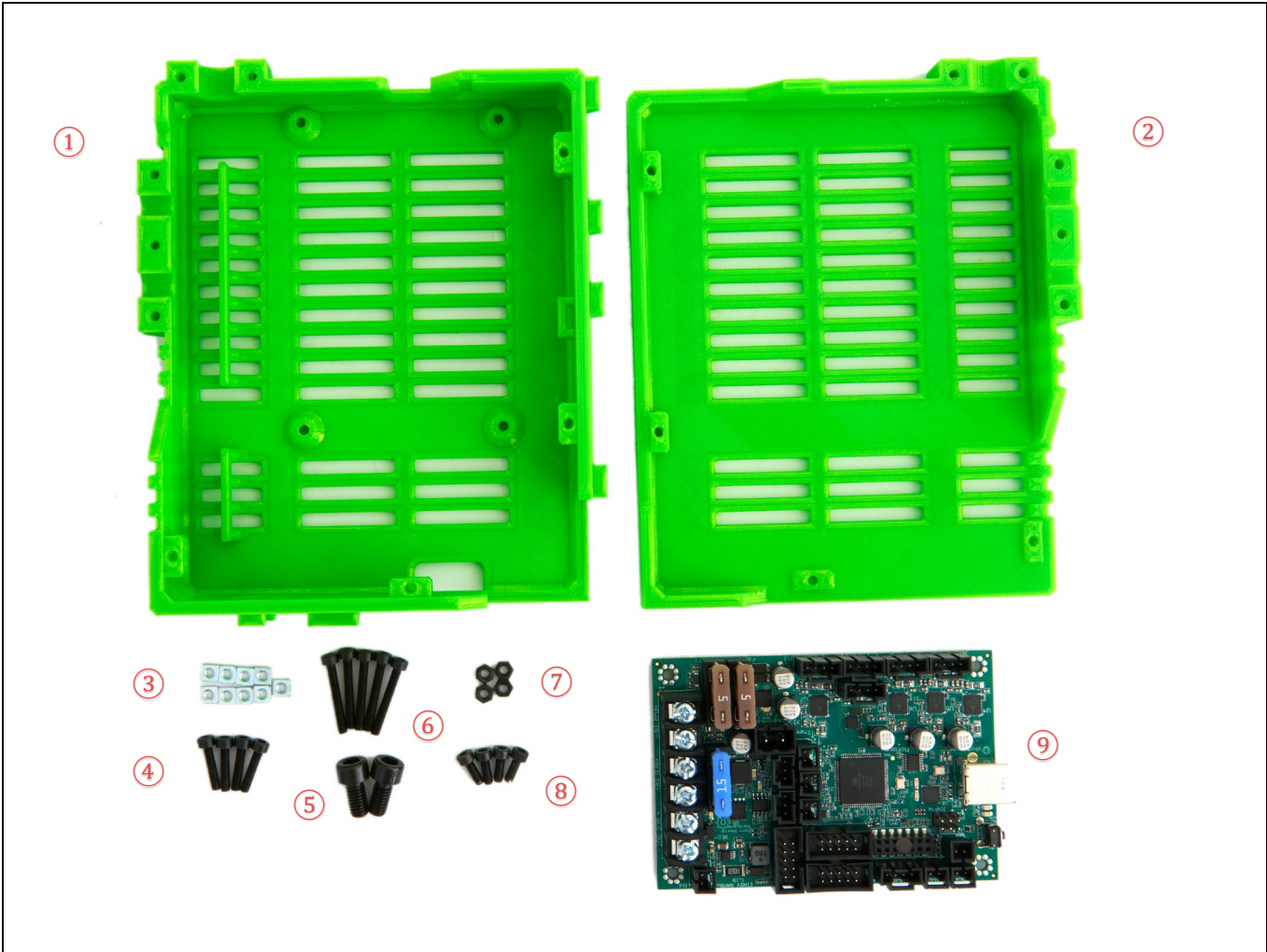

① Einsy Box	⑥ M3 x 22mm screw (5x)
② Einsy Box Cover	⑦ M3 hex nut (4x)
③ M3 Square Nut (9x)	⑧ M3 x 8mm screw (4x)
④ M3 x 14mm screw (4x)	⑨ Einsy board
⑤ M6 x 12mm screw (2x)	

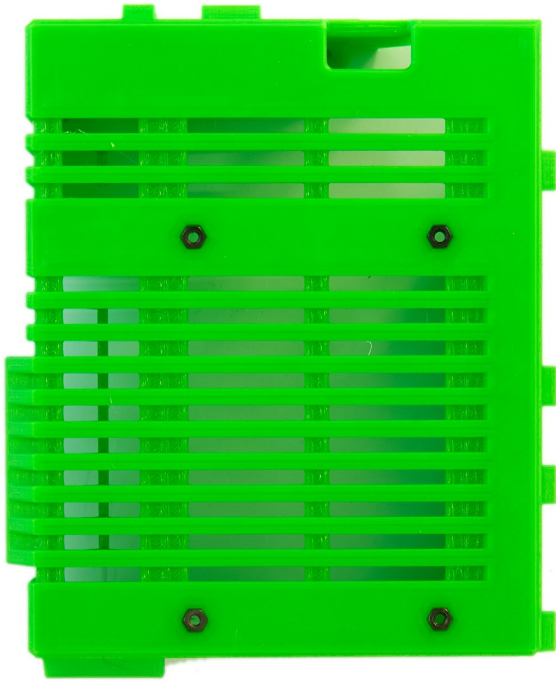

Preparation of the Einsky box:

Insert **4x M3 hex nuts** on the back of the Einsky box.

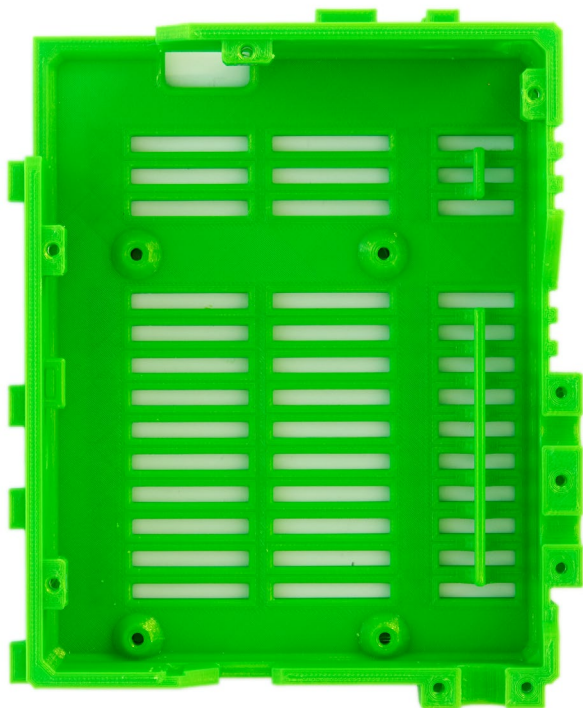

Insert **9x square nuts** in the slots on the inside of the box.

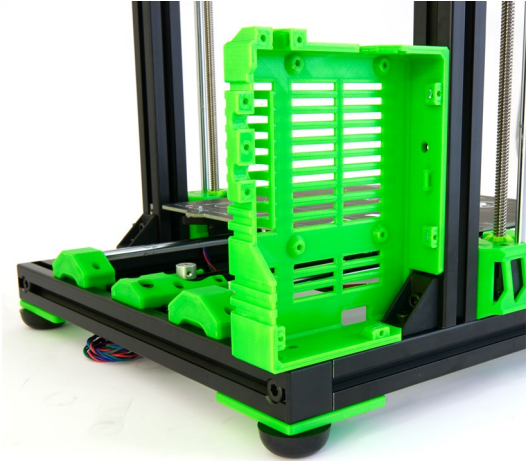

Attach the Einsky box to the frame. Make sure t-nut in the x-extrusion on back is aligned with the hole in the box.

For the z-axis is easiest to slide a small screwdriver through the hole an pick-up the t-nuts while inserting the box.

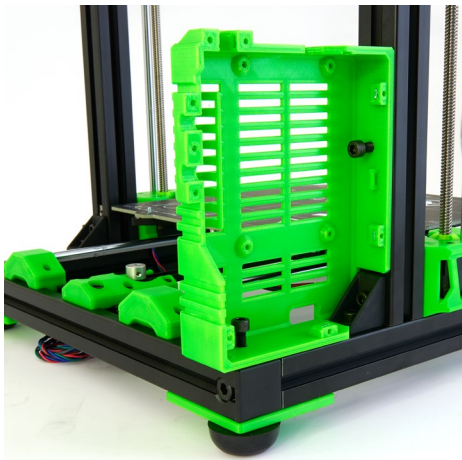

Insert **2x M6 x 12mm screws** into the holes on the z-extrusion and on x-extrusion in the back.

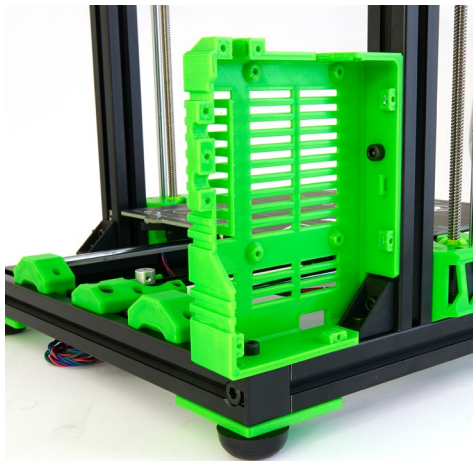

Tighten the screws gently.

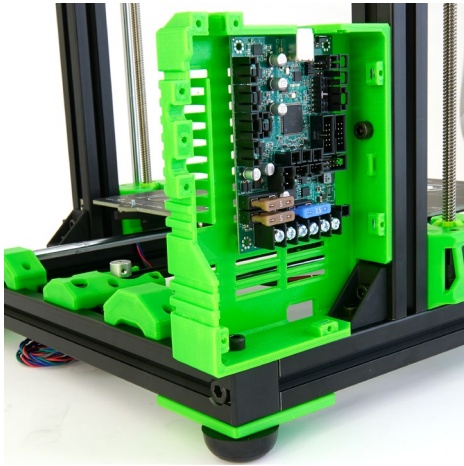

Insert the Einsy Rambo board into the Einsy box. Align with the four holes on the back.

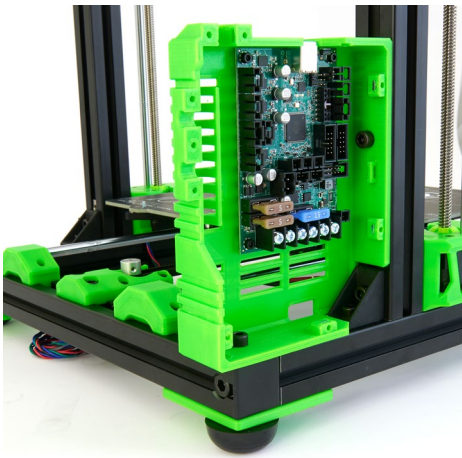

Use 4x M3 x 8mm screws to secure the board.

5.9 PSU ASSEMBLY

Please skip the next section when you own the 250W PSU.

5.9.1 PREPARATION OF MEANWELL RSP-320

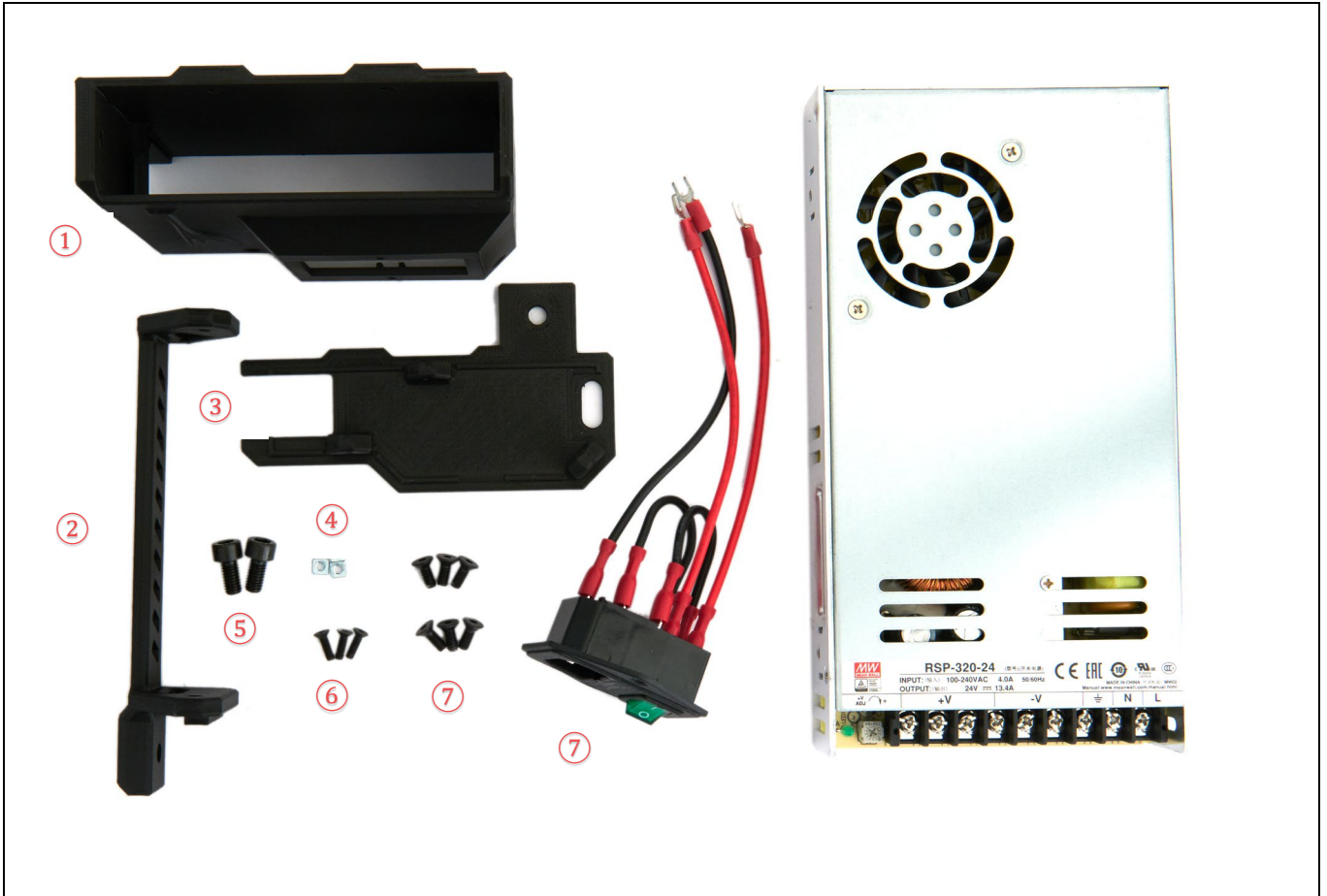

① Meanwell Cover	⑥ M3 x 10mm screw (5x)
② Meanwell Top Holder	⑦ M4 x 10mm screw (6x),
③ Meanwell Cover Bottom	⑧ Plug / Switch with cables
④ M3 Square nut (5x)	⑨ Meanwell PSU
⑤ M6 x 12mm screw (2x)	⑩ PSU Cables



Slide the cable of the combined switch / plug from the outside into the Meanwell PSU cover.

Use **2x square nuts** and **2x M3 x10 countersunk screws** to fasten the switch

Pay attention to the direction of the plug!



Open the protective flap on the PSU and loosen the first three screws from the right.

Attach the black cable to ground, and the two red cables to N and L (order of red cables is irrelevant).

Through the base, attach the red power cable to one of the three left positive terminals. Attach the black cable to one of the right three negative terminals. Do the same for the other power cable



Slide the PSU and the base together.



Screw it in place with **4x M4x10mm countersunk screws** on the front...

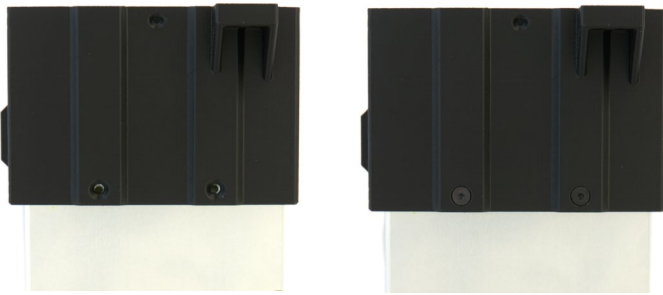

... the side ...

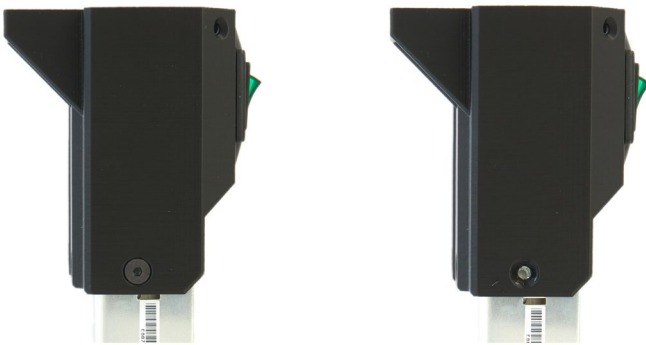

... and the back.

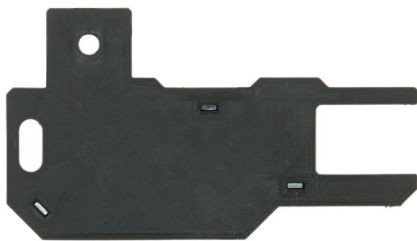

Insert **3x square nuts** into the bottom cover.



Slide the cable through the hole.

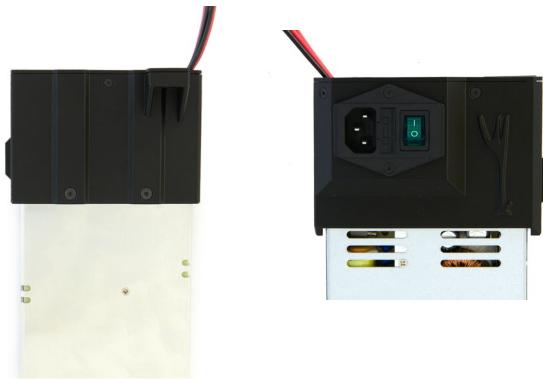

Use **3x M3 x 10mm countersunk screws** to secure the bottom on the cover.



Using **2x M4x10mm screws** install the top mount to the top of the PSU...

One in the front...



... and one in the back.

5.9.2 PREPARATION OF THE 250W PSU



Insert the switch into the PSU base in the orientation shown.

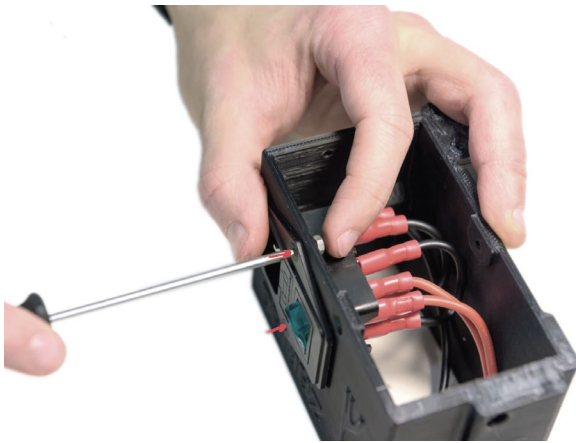

Using **2x M3x8mm countersunk screws** and **2x M3 hex nuts**, screw the switch in place.

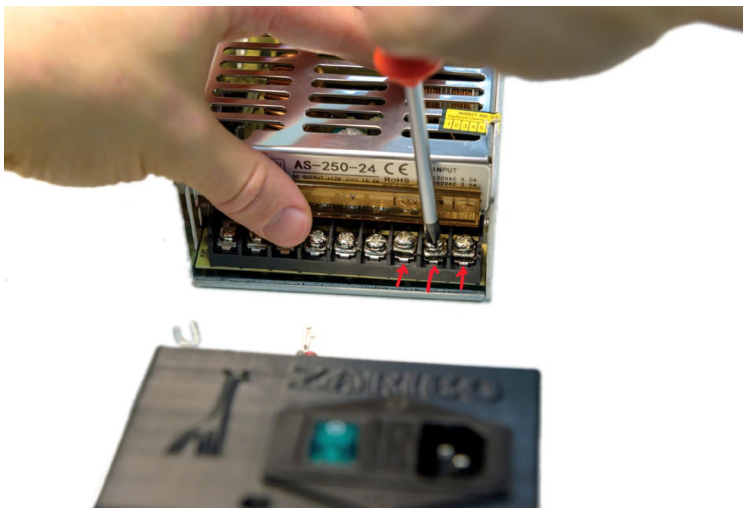

Open the protective flap on the PSU and loosen the first three screws from the right.

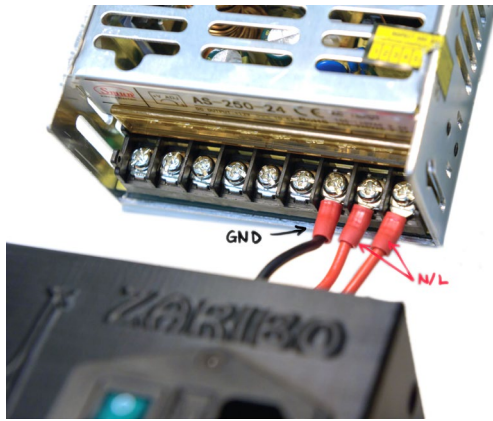

Attach the black cable to ground, and the two red cables to N and L (order of red cables is irrelevant).

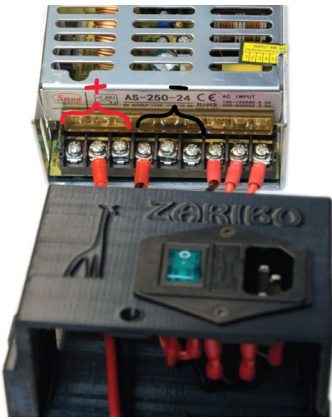

Through the base, attach the red power cable to one of the three left positive terminals. Attach the black cable to one of the right three negative terminals.

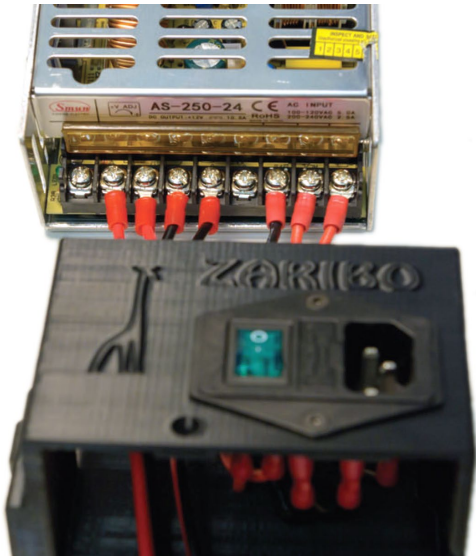

Do the same for the other power cable.

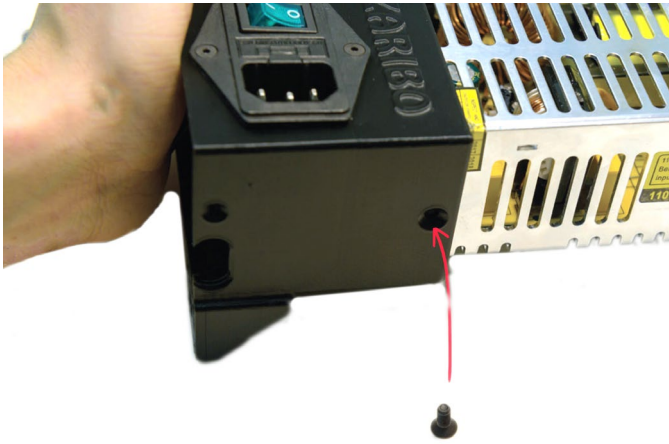

Slide the PSU and the base together and screw it in place with an **M4x10mm countersunk screw**.

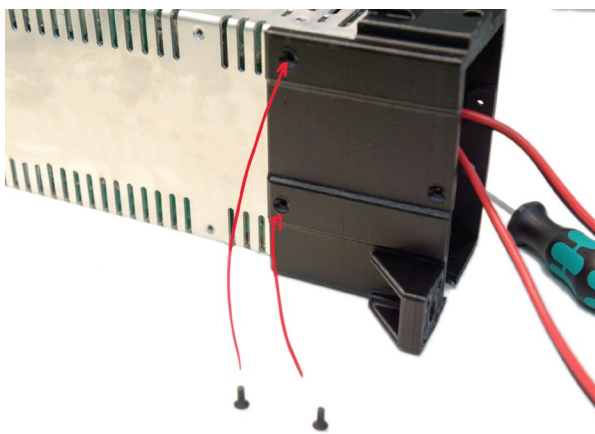

With **2x M3x8mm screws**, fasten the other side to the PSU.

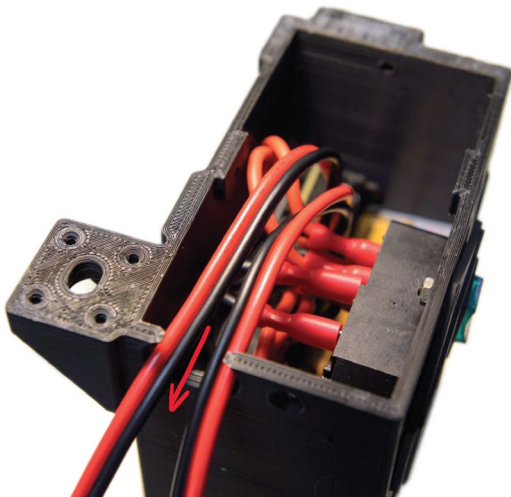

Route the two power cables through the opening in the side.

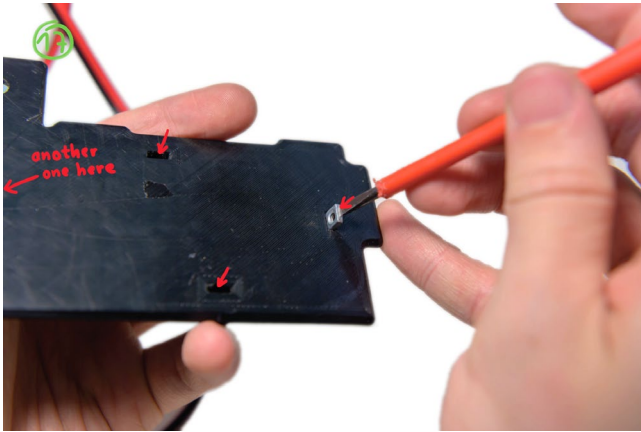

Insert a square nut into each of the four slots on the underside of the PSU base cover.

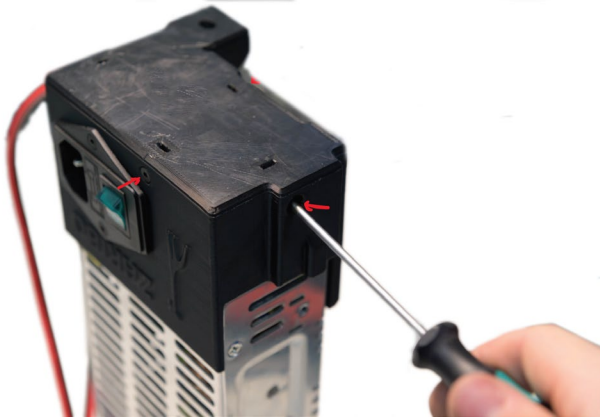

Through the PSU base, screw an **M3x10mm countersunk screw** into each of the square nuts.



Using **2x M4x10mm countersunk screws** install the top mount to the top of the PSU.

Use **1x M4x10 countersunk screw** on the other side of the top mount.

5.9.3 INSTALLATION OF THE PSU

We only show the installation of the Meanwell PSU. The installation of the 250W PSU works in the same way.



Use **1x M6 x 12mm screw** to fasten the top holder to the z-extrusion. Move the t-nut in the slot up with a small screwdriver.



Use another **M6 x 12mm screw** to fasten the box to the x-extrusion on the back.



PSU cable coming out the box of the bottom should be routed towards the Einsy box.

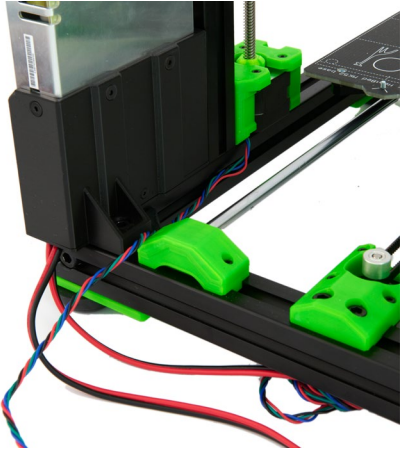

Cut an 8cm piece from the black extrusion slot cover.

Route the cable to the back.

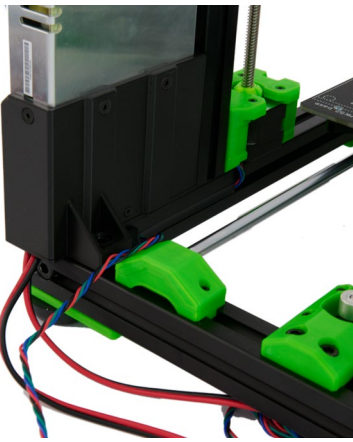

Using the 8cm extrusion slot cover, hide the right z-motor cable in the inside extrusion slot

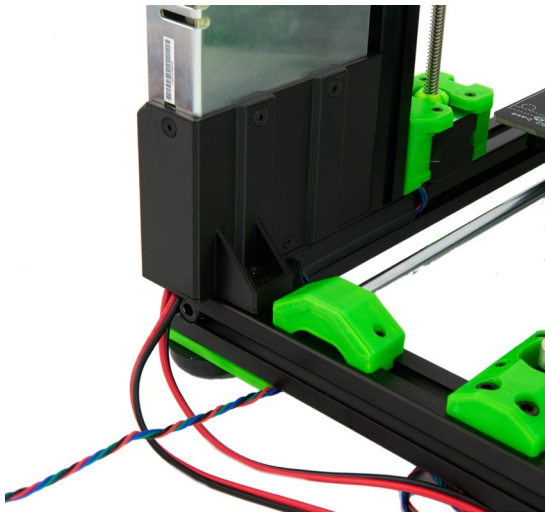

Route the cable under the rear x-extrusion and into the same rear slot.

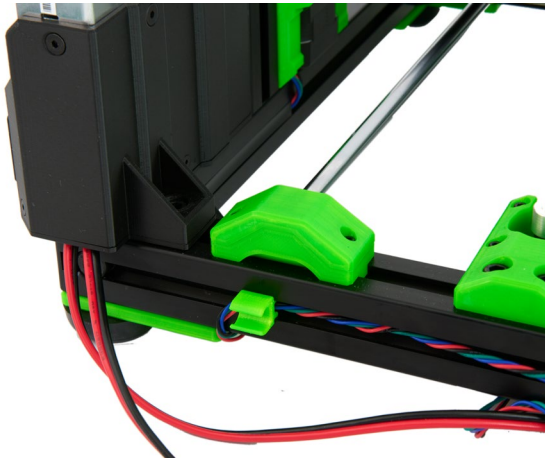

Fasten it in place with a plastic extrusion slot cover.

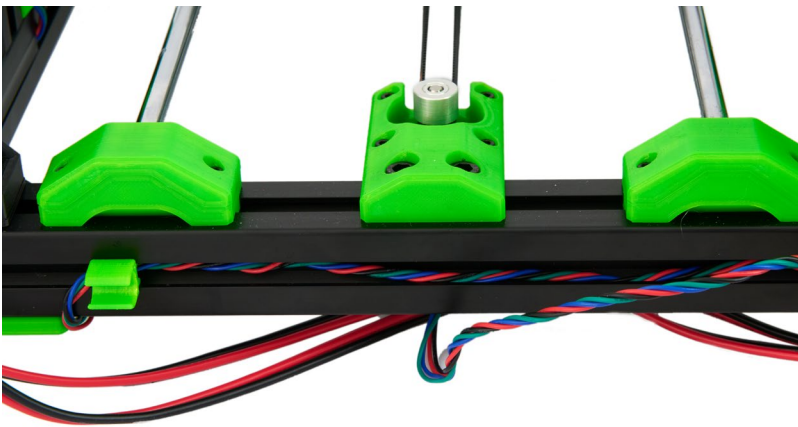

Route the cable of the y-motor under the x-extrusion.

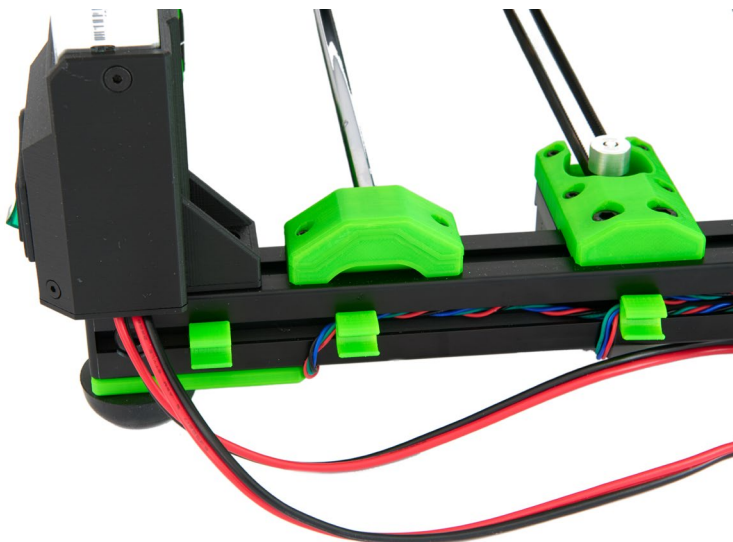

Fasten it in place with a plastic extrusion slot cover.

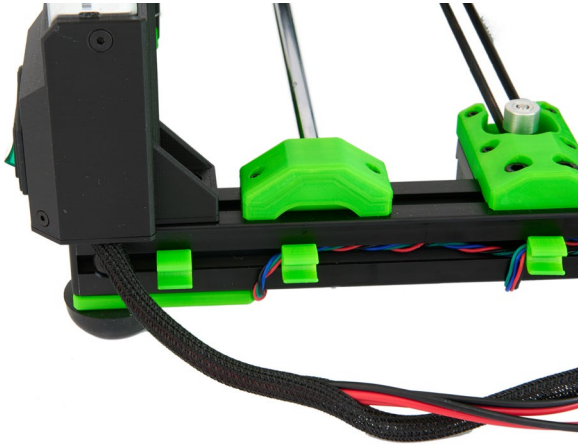

Cut a 40cm piece of the provided 6.4mm Techflex tube. Heat both ends shortly with a lighter.

Slide the PSU cable through the tube. Slide the slide about 1cm into the PSU box.



Fasten the Techflex tube with the cables inside to the PSU cable clips.

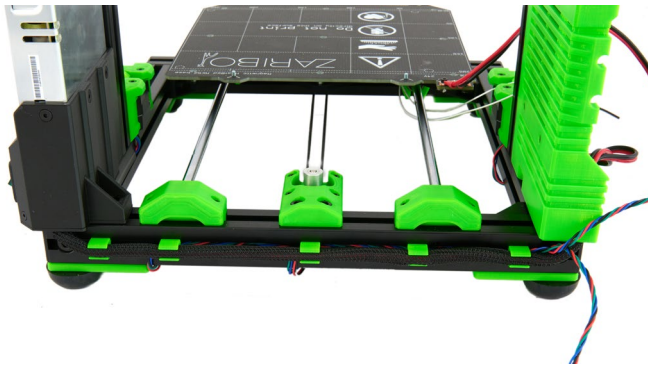

Add two more cable clips to the slot of the x-extrusion.

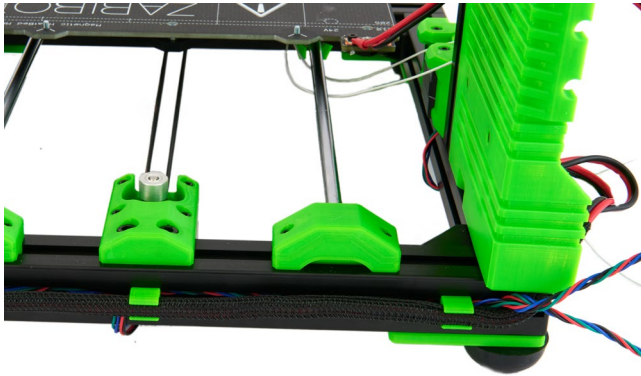

Route the Techflex tube through the bottom of the Einsky box.

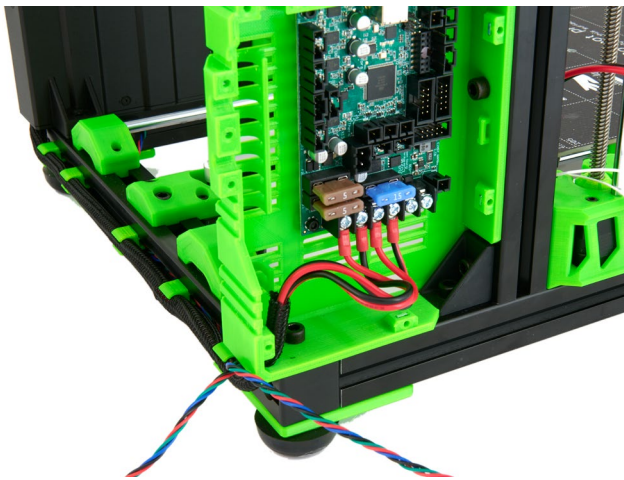

Connect the PSU cables to the Einsky board.

Pay attention to the polarity and connection! Wrong polarity may destroy the board.

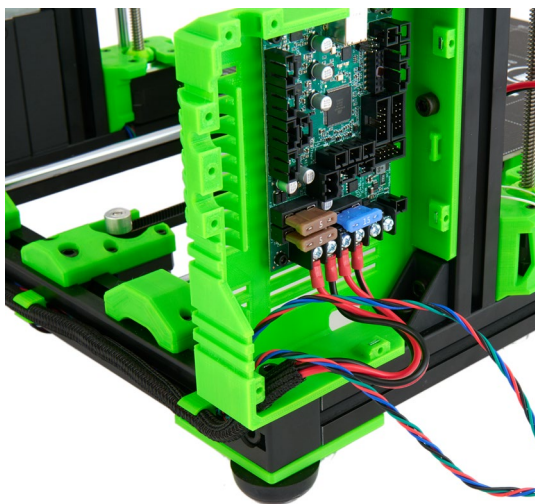

Route cable of the y-motor and the z-motor through the hole as well.

6 EXTRUDER ASSEMBLY

6.1 STOCK EXTRUDER

For the assembly of the stock extruder please refer to the manual of Rel.2 which can be downloaded [here](#).

6.2 BONDTECH EXTRUDER

Please follow the sub-section that corresponds to your hot end.

6.2.1 MOSQUITO HOTEND

(Photos in this section by Bondtech, thanks!)

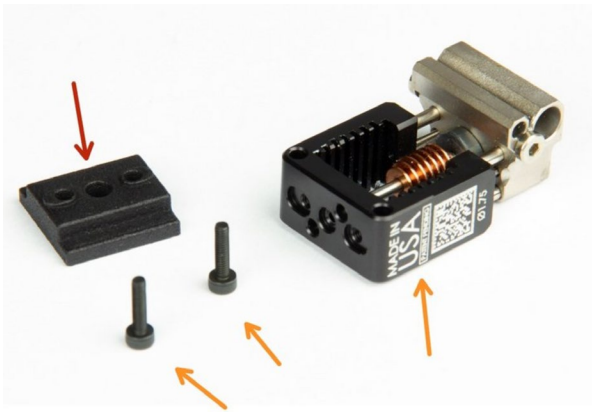
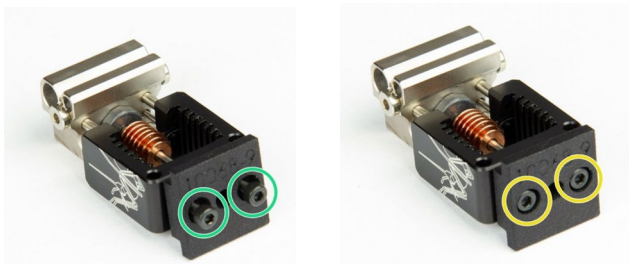
 <p>The image shows the components for the upgrade: a black mounting plate with two holes (indicated by a red arrow), two black M2 screws (indicated by orange arrows), and a Mosquito hot end assembly (indicated by an orange arrow). The hot end has a black body with 'MADE IN USA' and a QR code printed on it.</p>	<p>Parts supplied in the Bondtech upgrade kit: Mounting plate.</p> <p>Parts by Slice Engineering (not in the kit): Mosquito hot end; 2 x M2 screws.</p>
 <p>The image shows two views of the Mosquito hot end assembly with the mounting plate attached. The left view shows the front of the assembly with two screws (circled in green) securing the mounting plate. The right view shows the back of the assembly with two screws (circled in yellow) securing the mounting plate.</p>	<p>Attach the mounting plate on top of the Mosquito hot end using 2x M2x10mm screws.</p> <p>Use an 2mm allen key to tighten the screws.</p>

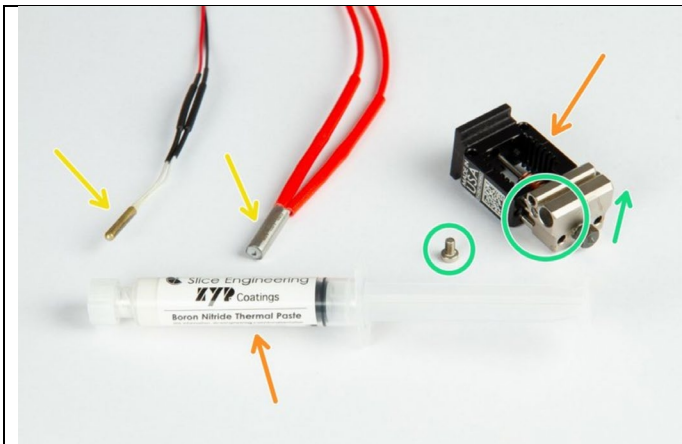

The following steps show installation of the heater and thermistor. It is highly recommended to use thermal paste to increase conductivity between the hot end and heater/thermistor.

It is important to use thermal paste that can handle the working temperature of the hot end!

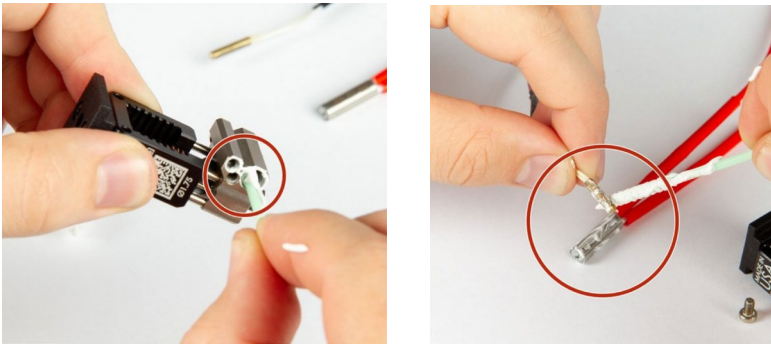

Proceed minding the orientation of the heat block.

Remove the screw that will hold the heater and thermistor in place using a 2mm allen key.

Apply paste inside the hot end and to the heater and thermistor.

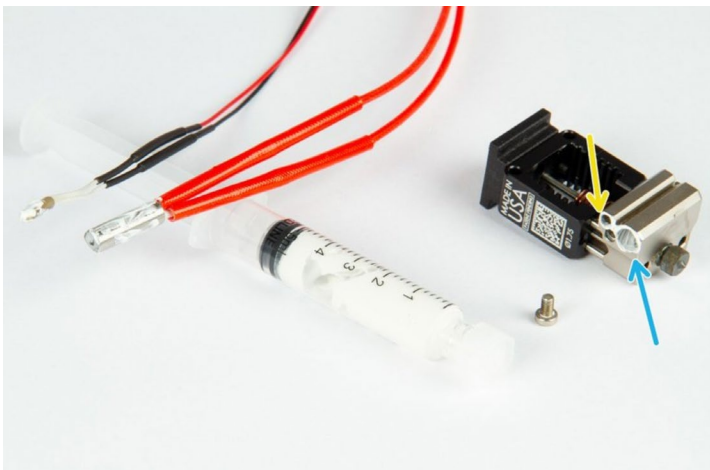

Insert the thermistor into the hole which is marked by a yellow arrow.

Insert the heater into the hole which is marked by a blue arrow.

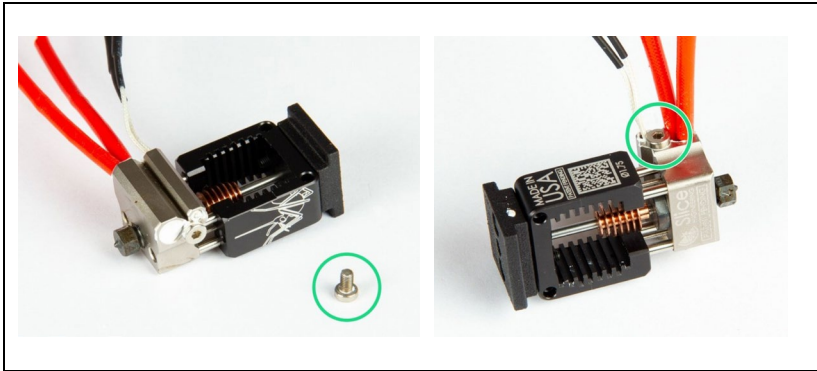
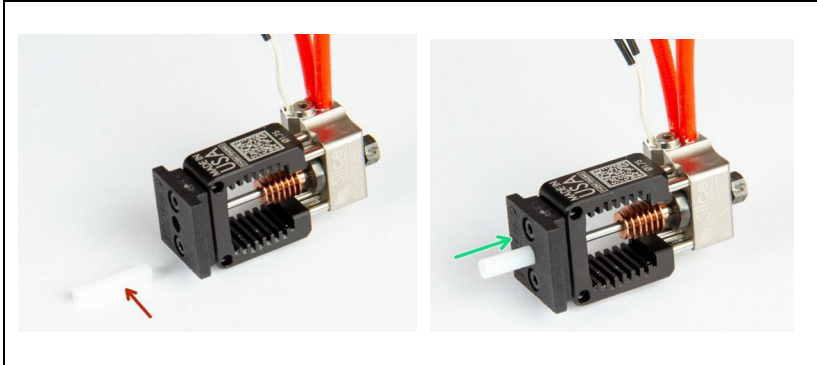
	<p>You can carefully rotate the parts inside the hot end to spread the paste evenly.</p> <p>Attach the screw and tighten it using an Allen Key.</p>
	<p>Install the PTFE tube:</p> <p>Parts supplied in the Bondtech upgrade kit: 18.7mm PTFE tube.</p> <p>Insert the PTFE tube and push until it's flush with the hotend.</p>

6.2.2 E3D HOTEND ASSEMBLY

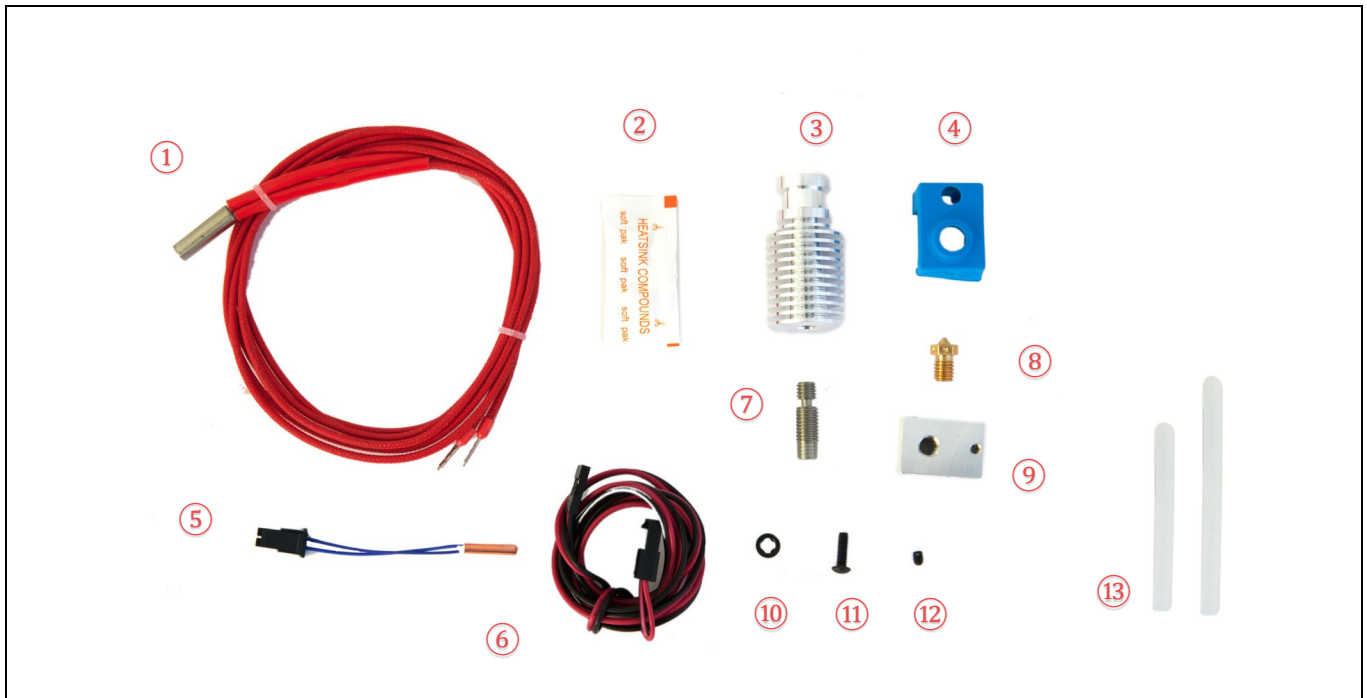

① Heater cartridge	⑧ Nozzle
② Thermal paste	⑨ Heatblock
③ Heatsink	⑩ Bowden coupling
④ Silicone sock	⑪ M3 x 10mm screw
⑤ Thermistor	⑫ M2 grub screw
⑥ Thermistor cable	⑬ PTFE tube 39mm and 50mm
⑦ Heatbreak	



Screw the nozzle into the heater block into the end closest to the thermistor holes. Unscrew the nozzle a 1/4 to a 1/2 turn.

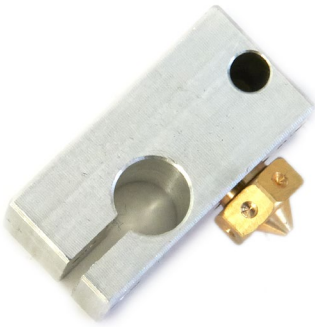

View from the side.

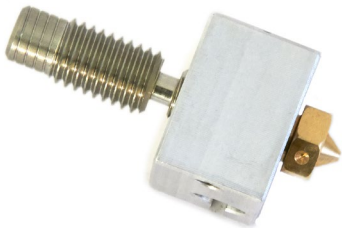

Screw the heat break into the other side of the heater block so it is butts up against the nozzle.



Gripping the heater block with a spanner, tighten the nozzle with a second spanner.

Do not over-tighten, we are going to tighten it up later when the heater block is hot.



The thermal compound should be spread evenly across the threads of the heat-break, only on the cold-side of the heat-break that screws into the heat-sink.



Screw the heatsink onto the heartbreak by gripping the heatsink in one hand and the heater block in the other. It only needs to be tightened up hand tight. Do not overtighten.

	<p>Insert the bowden coupling to the top.</p>
	<p>Insert the provided PTFE tube. Make sure it is fully inserted</p> <p>For Bondtech extruder only:</p> <p>Measured from the metal to the tip of the tube it should protrude about 6.5mm.</p> <p>For stock extruder only:</p> <p>Measured from the metal to the tip of the tube it should protrude about 17.5mm.</p>
	<p>Using the allen screw, fasten the thermistor in place with the M2 grub screw. Only tighten this as much that it cannot fall out, as tightening it too much will result in a broken thermistor.</p>

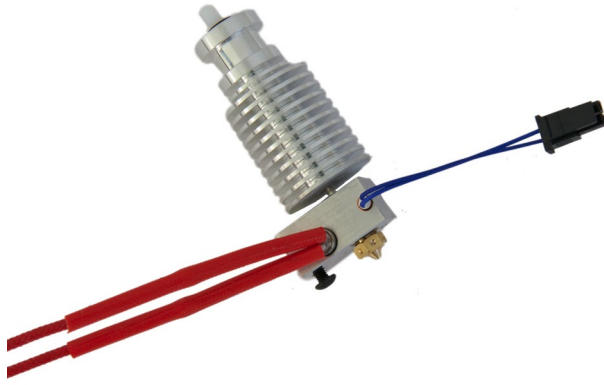

Insert the heater cartridge with the leads exiting the block the same side as the thermistor. Centre the cartridge in its hole in the block.

Tighten the clamping portion of the heater block around the heater cartridge with a **M3x10 screw**.

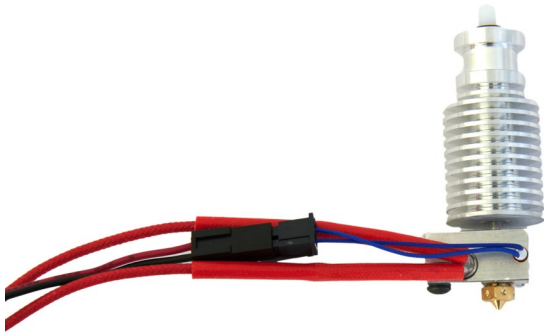

This is the complete assembled hot end.

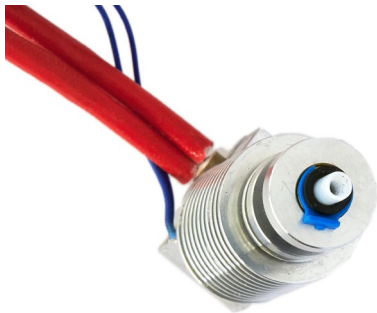

Insert a push fit clip between the hot end and the collet

6.2.3 BONDTECH EXTRUDER PREPARATION



① Bondtech Extruder	⑩ M3 x 14mm screw
② Fan Shroud	⑪ M3 x 30mm screw
③ x-Carriage	⑫ M3 x 35mm screw
④ Filament Sensor	⑬ Extruder gear
⑤ M2 x 12mm screw	⑭ Thumbscrew
⑥ Square nuts (3x)	⑮ Large Magnet
⑦ M3 x 10mm screw	⑯ Small Magnet
⑧ Lever	⑰ M3 nut (8x)
⑨ Holder with 7mm ball screw	



Open the extruder body.

The dowel pin of the idler will stick on one side of the parts. Exact side does not matter.



Insert the small magnet into the lever. If it's sitting too loose you must use some glue to fasten it.

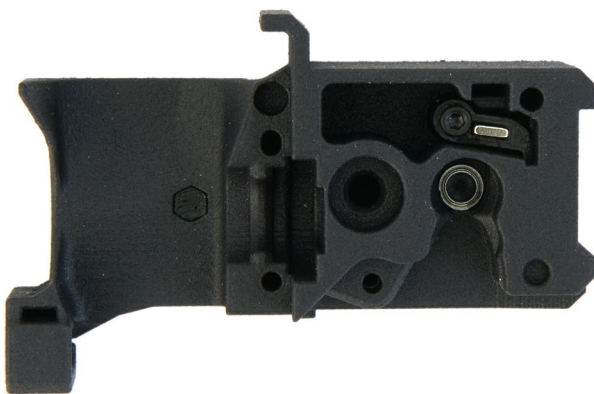

Use **1x M3 x 16mm screw** and screw the magnet lever all the way in and then loosen it a bit (half of a turn) so it can rotate freely.

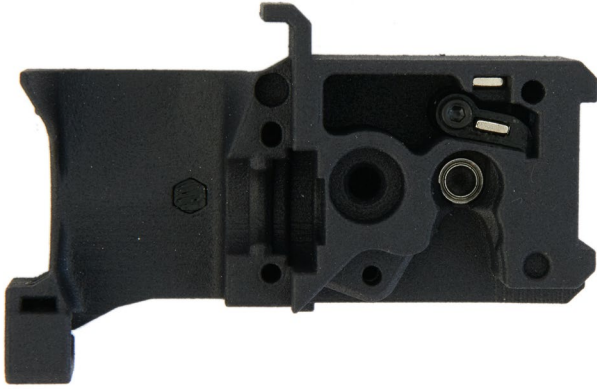

Insert the bigger magnet into the slot next to the lever. Make sure the magnets repel each other.



Remove the small screw cover in the lower part of the extruder body.

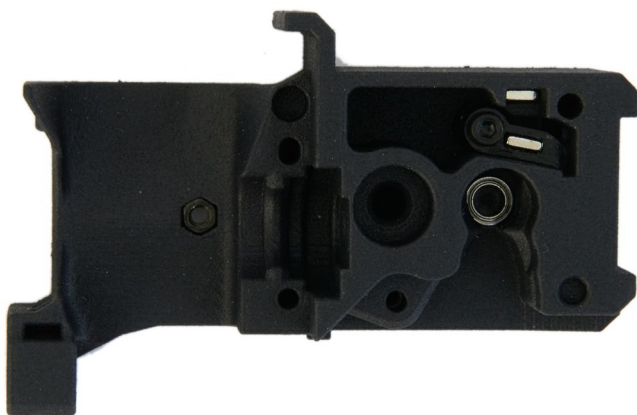

Insert a **M3 hex nut**. We'll use that later to secure the nylon filament.

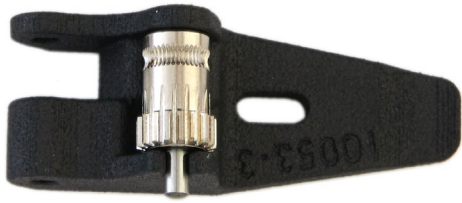

Align the gear with the hinge as shown in the photo and press the shaft down until you hear the click.



Carefully press the shaft in place.

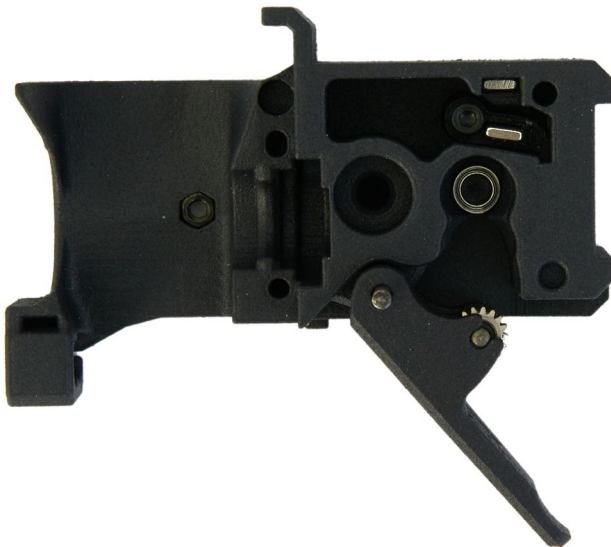

Install the hinge to the extruder rear using the 3x32mm shaft.



Remove the shaft with the black plastic gear from the extruder body.

Slide on the motor gear and make sure the grub screw is aligned with the flat side of the shaft.

Fasten the grub screw by a few rotations so that cannot rotate but can move back and forth.



Insert the shaft assembly into the back of the extruder body.

Make sure the grooves are aligned with the filament path and fasten the grub screw.

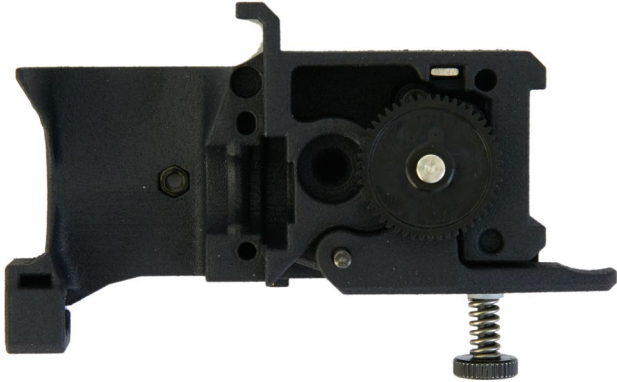

Install the thumbscrew.

6.2.3.1 E3D HOT END INSTALLATION

Please skip this section if you own the Mosquito hot end.



Add a small piece of tape, 5x40mm on the inner ring. This will ensure that the hot end cannot rotate.

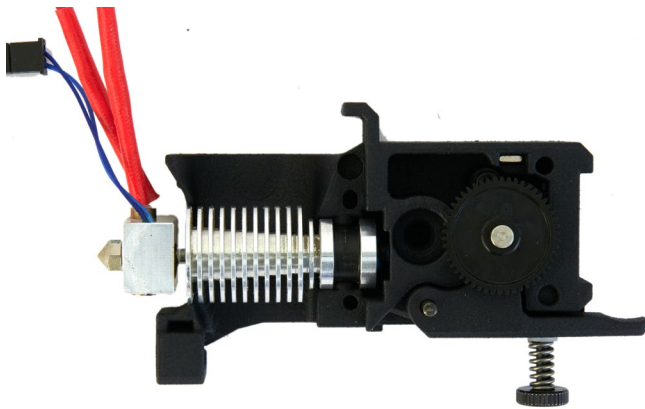

Install the hot end into the extruder rear. Start with the heat block at an angle and push the hot end down and upwards (to the right in the picture).



Insert **1x square nut** into the right hole of the photo. Make sure the one on the left is present.

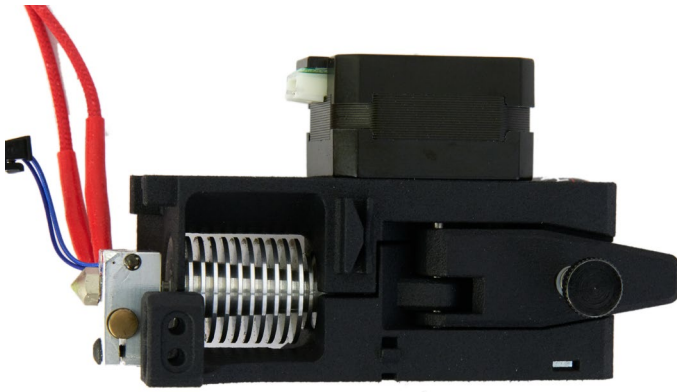

Attach the front onto the rear part. Push the hot end upwards to align the neck correctly.

Ensure everything is aligned and carefully clamp the parts together.

Important: The parts should fit together easy. Do not use any excessive force!

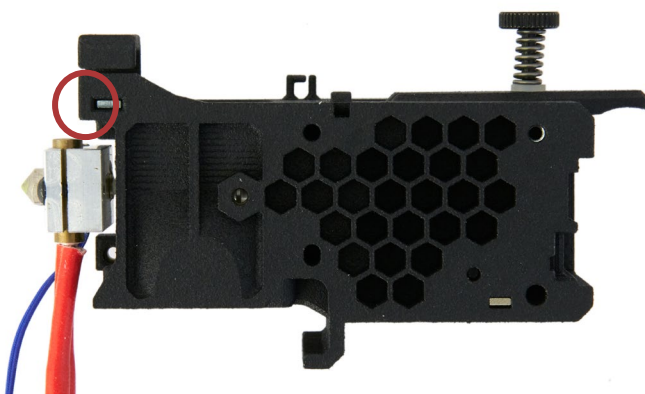

Insert **1x square nut** on the back of the extrude, at the position with the circle.

6.2.3.2 MOSQUITO HOT END INSTALLATION

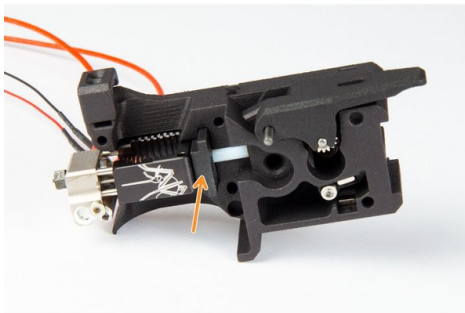
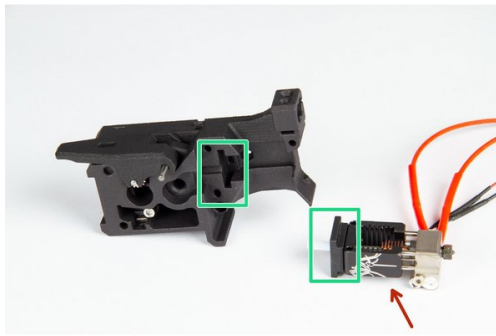

Proceed minding the orientation of the heat block and the housing.

Align the mounting plate with the groove in the Rear Housing part.

Push on the mounting plate until it's fully seated inside the Rear Housing.

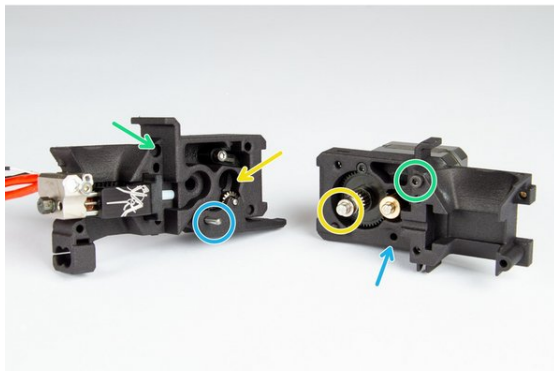

Check all parts are in place before performing this step.



Perform the clamping minding these alignments:



The main shaft's tip must align with the bearing hole inside that rounded hole.

The head of this screw goes into that rounded groove.

The hinge shaft must align with the matching hole.

6.2.4 INSTALLING THE FANS AND THE PINDA PROBE

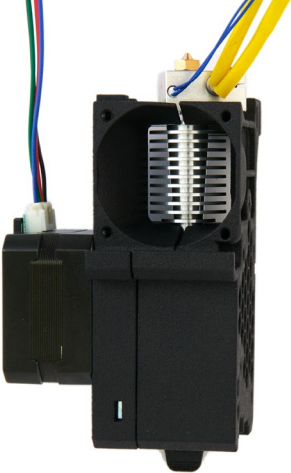
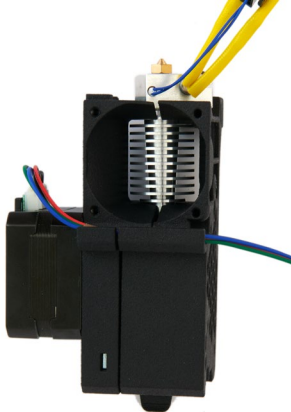
The installation of fans and PINDA is identical for both hot end versions. We only show photos of the E3d version.

	<p>Attach the motor cable to the extruder motor.</p>
	<p>Route the cable through the slot of the extruder body.</p>
	<p>Attach the Sunon fan to the extruder body as shown. Motor cables should sit above the fan. Use 4x M3 x 16mm countersunk screws to fasten the fan. Use a countersink to ensure a perfect fit of the screw.</p>

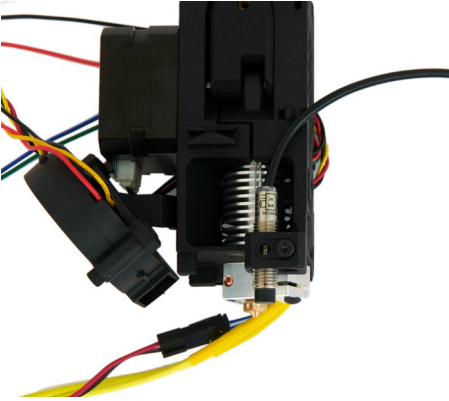
	<p>Insert two M3 hex nut into the holder for the radial fan.</p>
	<p>Attach the holder to the extruder front. Secure it with a M3 x 10mm screw.</p>
	<p>Attach the radial fan. Use two M3 x 20mm screws and a washer on each screw.</p>
	<p>Insert the PINDA probe into the hole closest of the holder. to the radial fan. Secure it with a M3 x 12mm screw.</p> <p>Make sure tip of the PINDA sit BELOW the nozzle. We adjust the correct position later.</p>

6.2.5 INSTALLATION OF THE FILAMENT SENSOR

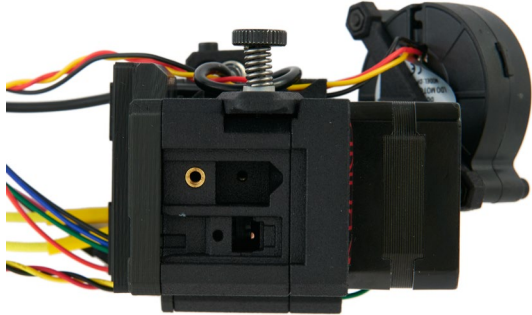
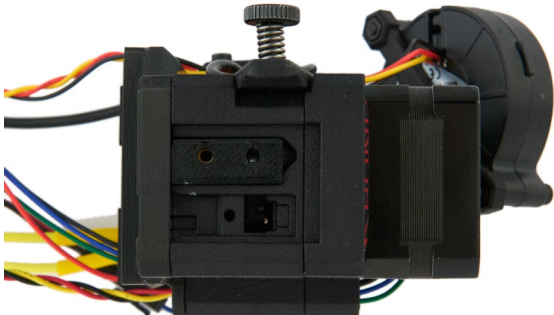
	<p>Insert the 7mm steel ball into the holder.</p>
	<p>Set the extruder upright.</p> <p>Screw in the thumbscrew hand tight. Loosen by 3-4 rotations.</p>
	<p>Insert the housing into the top of the extruder. Push it into the hole gently.</p>

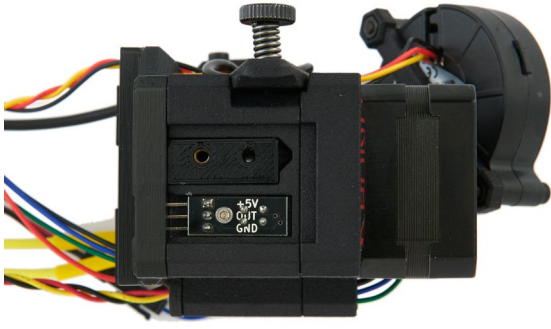

Insert the filament sensor. Fasten it with **1x M2 x 8mm screw**.

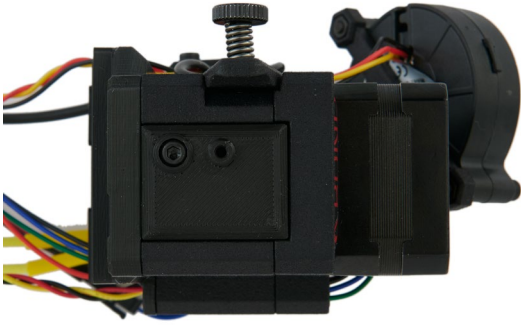

Secure the cover with **1x M3 x 10mm screw**.

6.2.6 INSTALLING THE X-CARRIAGE



Insert **7x M3 hex nuts** into the back of the x-carriage.

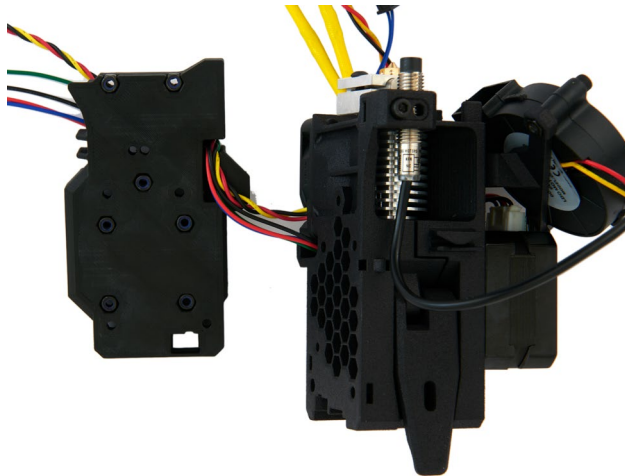

This is the correct orientation of the x-carriage. Route the cable on each side through the slot of the carriage.

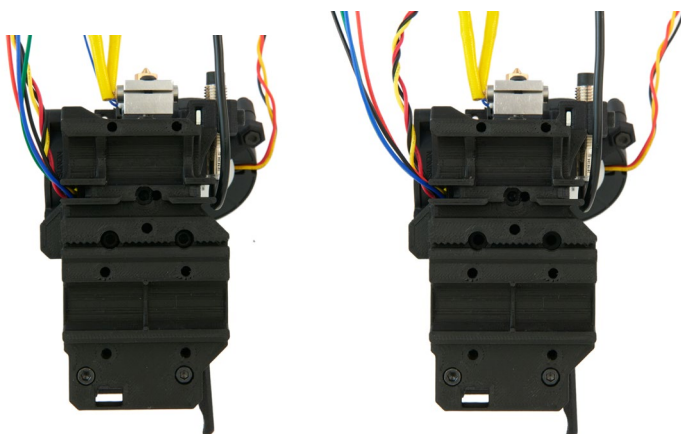

Fasten the x-carriage to the Bondtech extruder with a **M3 x 10mm screw** in the lower right hole on the photo.

Fasten the x-carriage to the Bondtech extruder with a **M3 x 40mm screw** in the lower left hole on the photo.

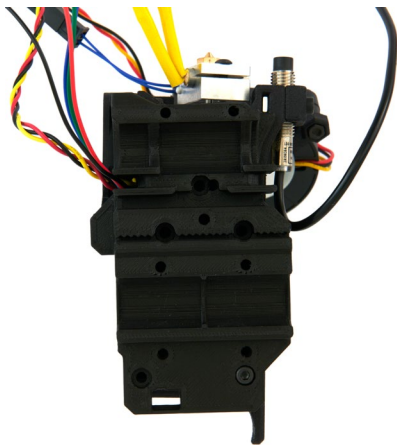

Fasten the x-carriage to the Bondtech extruder with a **M3 x 30mm screw** in the middle right hole on the photo.

Fasten the x-carriage to the Bondtech extruder with a **M3 x 35mm screw** in the middle left hole on the photo.

6.3 EXTRUDER INSTALLATION

6.3.1 STOCK EXTRUDER

For the installation of the stock extruder please refer to the manual of Rel.2 which can be downloaded [here](#).

6.3.1 BONDTECH EXTRUDER

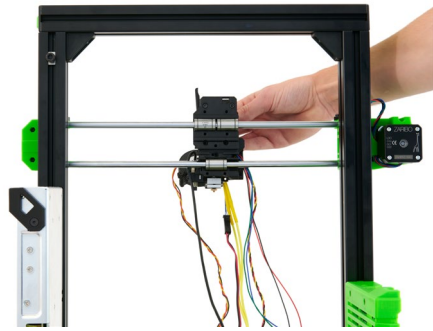
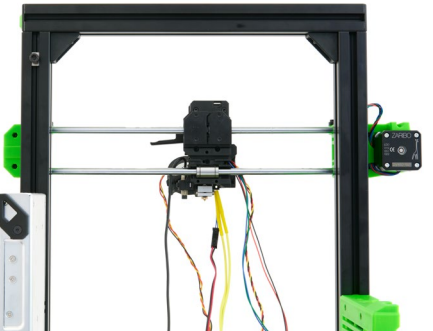
	<p>Move the x-axis to the upper third of the z-axis to get some workspace.</p> <p>Place the bearings roughly as seen on the photo.</p>
	<p>Attach the assembled extruder to the bearings. Make sure the slide into the holes the x-carriage.</p>
	<p>Use 4x M3 x 18mm screws to fasten the top x-carriage back part. Gently screw them in and don't overtighten.</p> <p>Make sure the extruder can run freely and without too much resistance on the x-rods.</p>

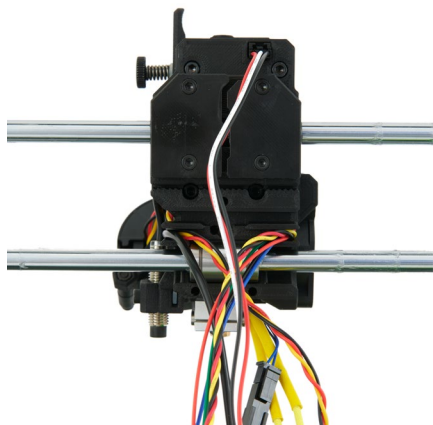

Route the cable through the slots on the side of the x-carriage.

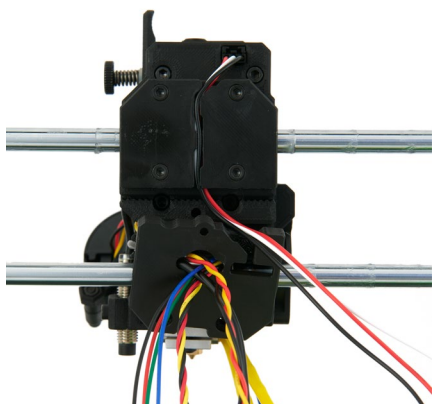

Route all cable through the bottom part.
Leave out the filament sensor cable for now.

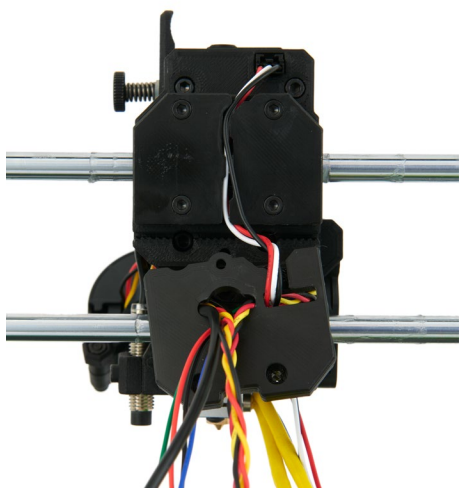

Now slide the cable of the filament sensor from the outside to the inside through the slot on the right.

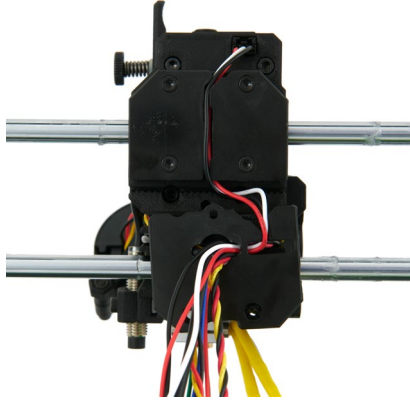

Slide the filament sensor cable through the hole in the middle as well.

Type	Caribou		
	220	320	420
Nylon	47 cm	57 cm	67 cm
12.7mm Techflex Tube	45 cm	55 cm	65 cm

Prepare the provided nylon filament and Techflex according to table with respect to the model you are building.



Sharpen one side of the nylon filament with a sharp knife.

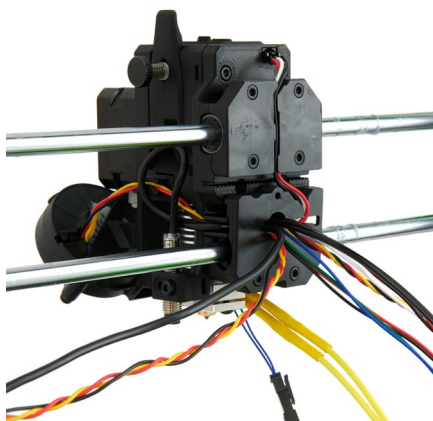

Insert the sharpened side of the nylon filament into the left hole in the center of the x-carriage.

Once again make sure that all cables are properly routed through the slots of the x-carriage.

**No cable should stay out on the side.
No cable should be pinched.**

Fasten the bottom cover with **2x M3 x 18mm screws.**

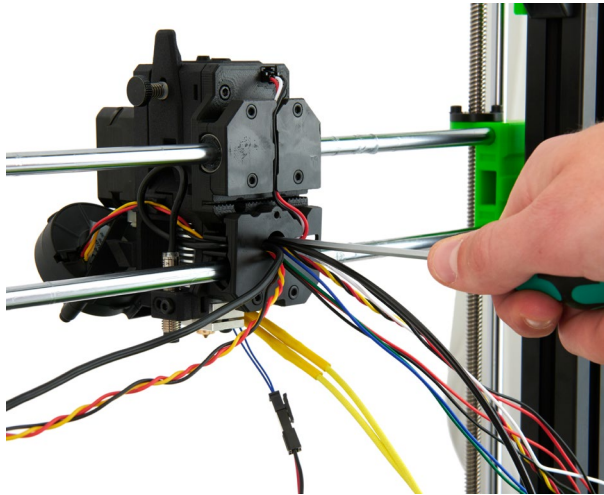

Secure the nylon filament by inserting **1x M3 x 10mm** screw.

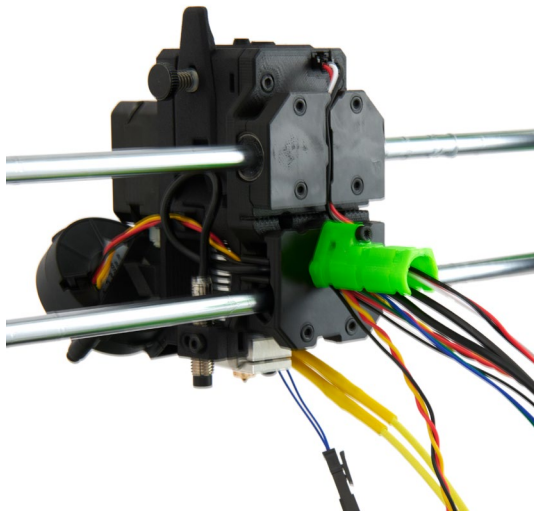

Fasten the x-cable holder with **1x M3 x 35mm** screw.

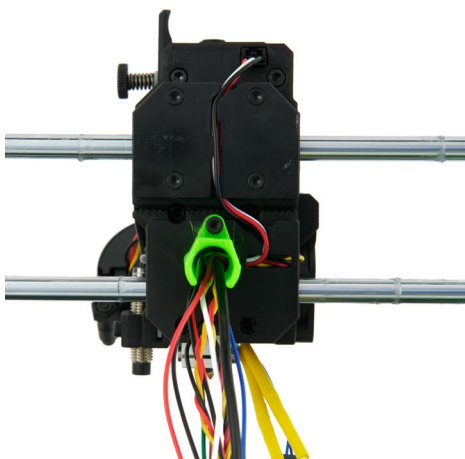

Align the cables and the nylon filament with the cable holder.

Leave out the heat cartridge and thermistor cable for the moment.

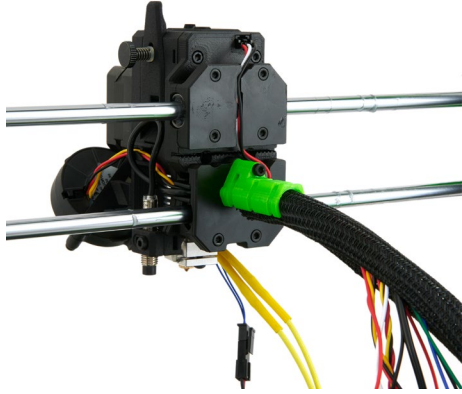

Slide the cables and nylon filament into the 12.7 Techflex tube that you prepared earlier.

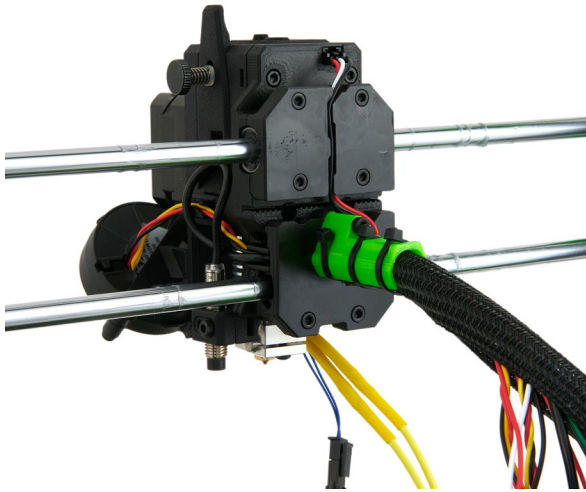

Slide the tube fully into the x-cable holder and secure it with zip ties.

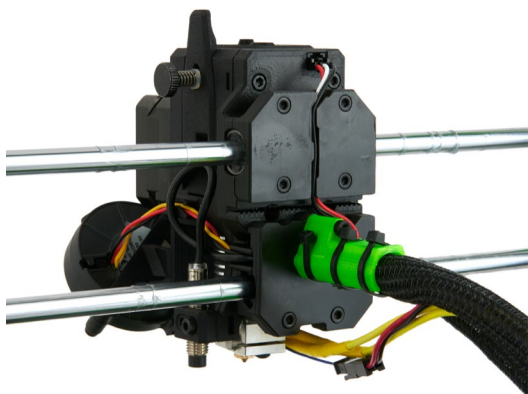

Now insert the heat cartridge and thermistor cable as well.

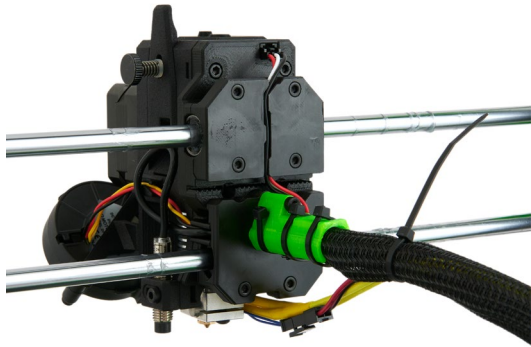

Secure the cables with a zip tie.

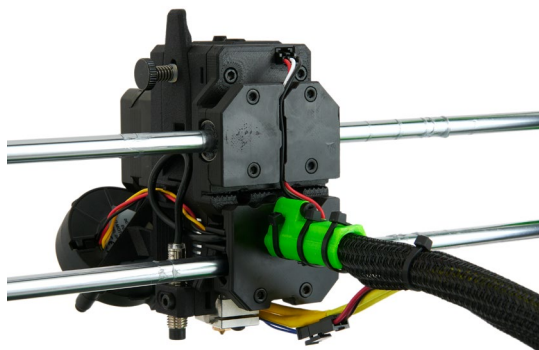

Cut off the end of the zip tie. Make sure the heat cartridge and thermistor cable are on the side to the heat block and are above the nozzle.

Be very careful with the thermistor cable. Don't pull on it!



Move the x-axis all the way up and the extruder to the left side (from behind) of the frame.

Route the tube with cables to the Einsy box.



The Techflex tube should now sit loosely between Einsky box and extruder.

Remove the cable from the tube so that the tube only enters at the top of the box.



Cut the Techflex tube and nylon filament to length.

DON'T cut the PINDA cable by accident!



Heat up the end of the Techflex tube.

6.4 X-BELT INSTALLATION

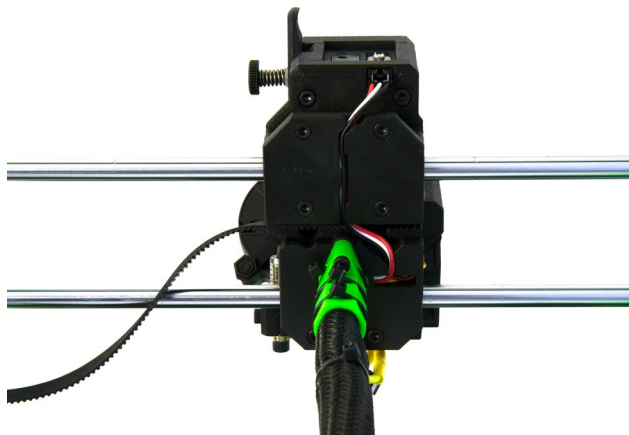

Start by inserting the belt on the left side of the x-carriage. The belt should be positioned on the left half of the slot.

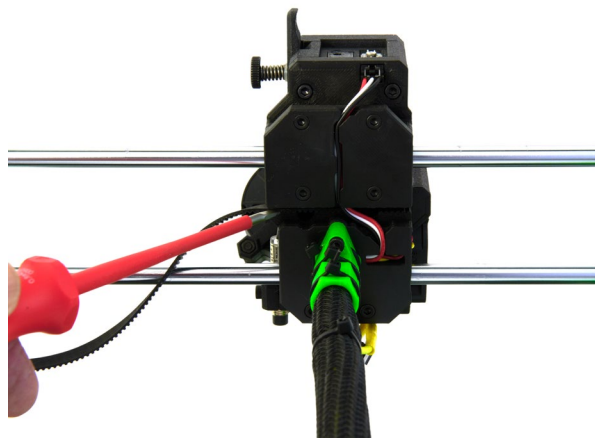

Carefully slide it in with a flat screwdriver. Don't use excessive force.

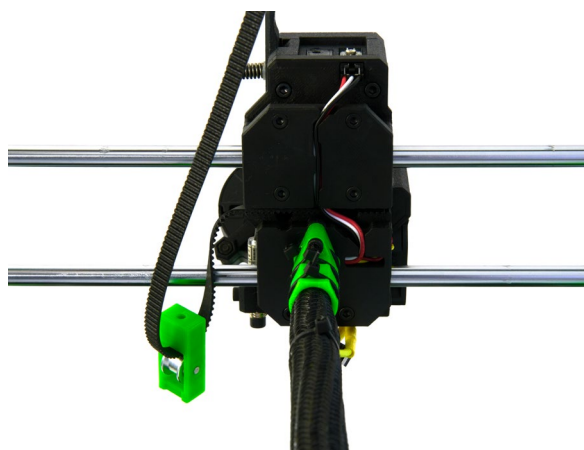

Slide in the xy-belt tensioner insert. Pay attention to the direction.



Insert the xy-belt tensioner insert into the idler-

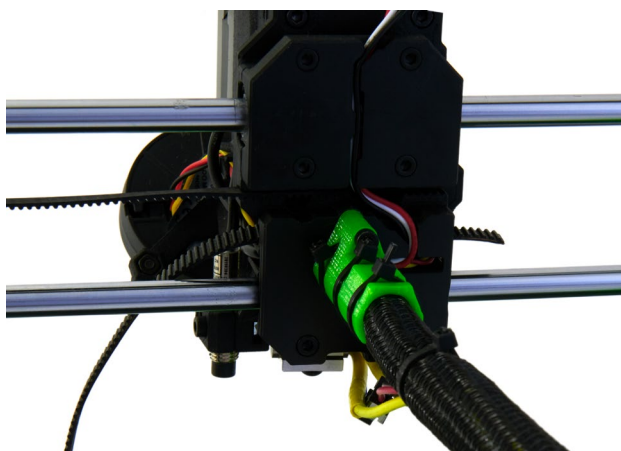

Now slide the belt through the lower part of the x-carriage.

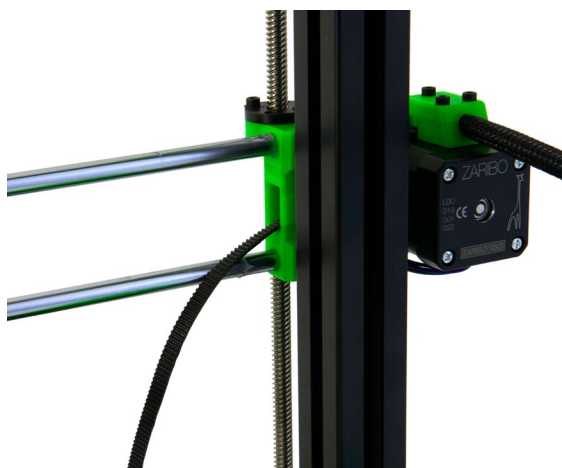

Next slide it through the motor holder.

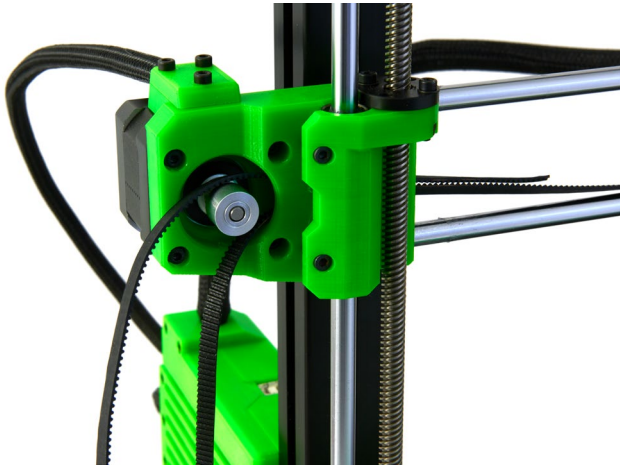

Slide it from below over the pulley of the x-motor.

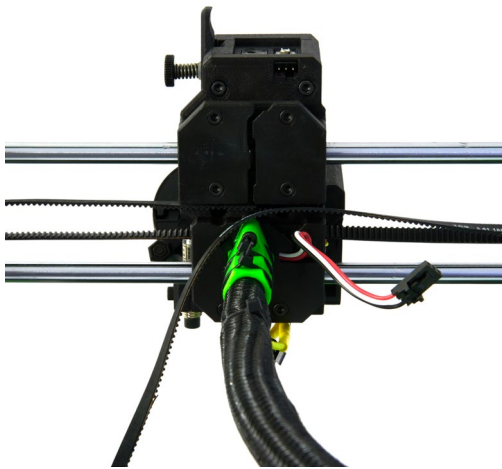

The belt should now arrive back at the x-carriage like this. Make sure it's not twisted or turned.

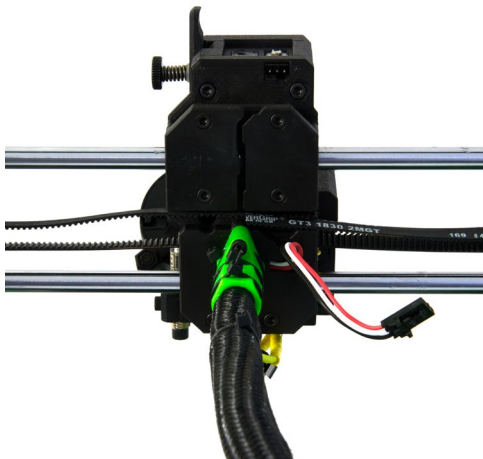

Now cut it to the correct length that the belt end where the other part started.

It doesn't have to be tight at this point.

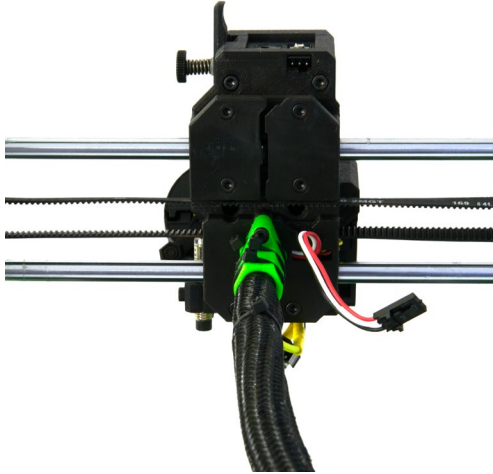

Slide the belt into the x-carriage. A flat screwdriver may help again.

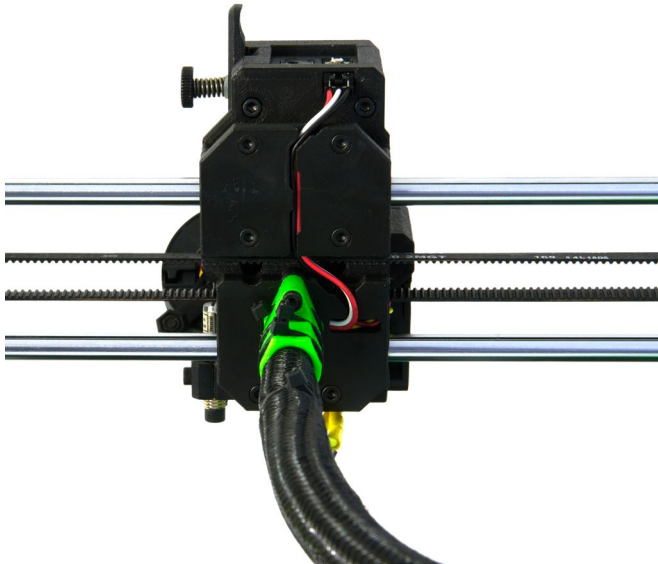

Finally use the screw in the idler to tighten the belt. It shouldn't be very tight nor too loose. The belt should make a sound of a bass guitar when the extruder is on one side of the frame as you pull on the lower part.

Put the filament sensor cable back into position.

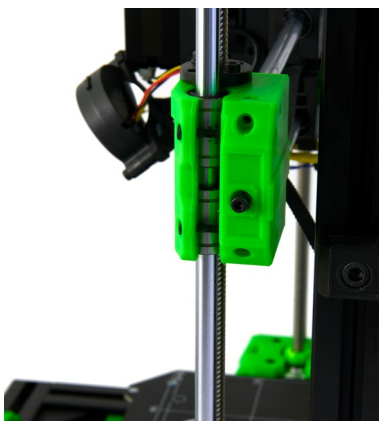

Use a **M3 washer** and a **M3 x 18mm screw** to fasten the insert. For the moment only fasten it by about 2-3 rotations.

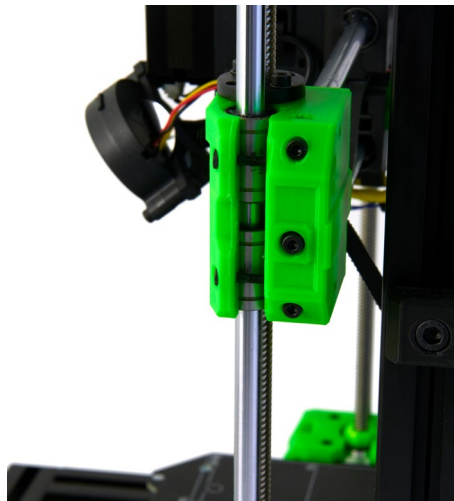

Insert **2x M3 x 12mm screws**. When your printed parts sit loose on the rods you may tighten them a bit

DON'T tighten them too much!!!

6.5 LCD ASSEMBLY

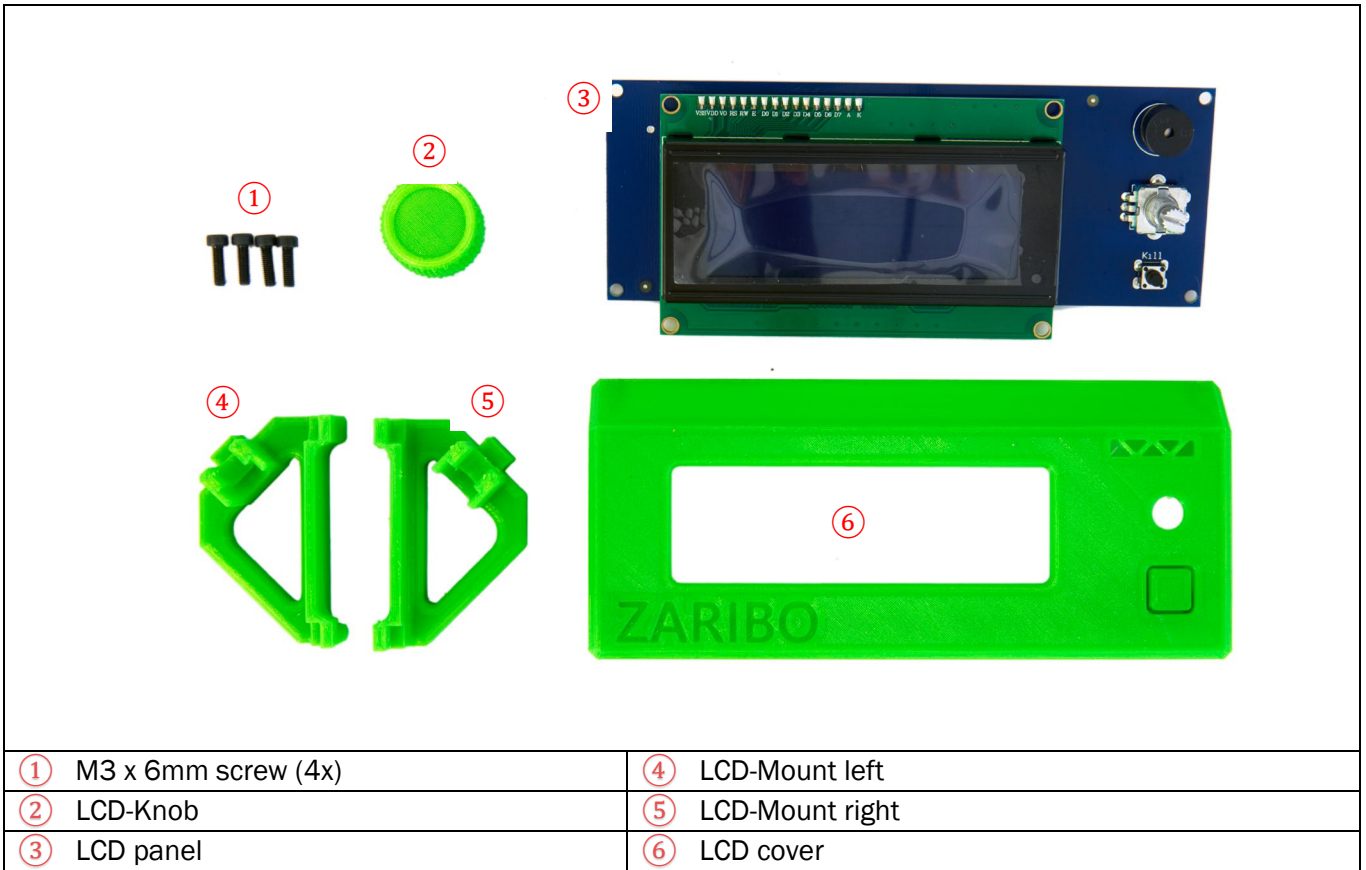



Insert the LCD panel into the LCD cover.



Place the LCD mounts onto the LCD panel. You may have to push them into the cover gently. Pay attention to the orientation. Mounts for attaching the LCD to the frame must point to the outside.



Place **4x M3 x 10m screws** into the holes in the corner.

Tighten the screws gently.



Make sure that you hear a clicking sound when pressing the pin of the LCD and pressing the reset button.



Put on the control button. While pressing the button on the pin press against the panel from behind.



Carefully remove the plastic foil in front of the display.

7 CABLE ROUTING

See appendix for a detailed diagram of the connectors of the Einsy box.

7.1 X-AXIS

Type	Caribou		
	220	320	420
Nylon	37 cm	47 cm	57 cm
6.4mm Techflex Tube	35 cm	45 cm	55 cm

Prepare the provided nylon filament and Techflex according to table with respect to the model you are building.



Move the x-axis to the top.

Make sure the cable of the x-motor is routed through the clip on the left (viewed from behind) of the motor.

Insert **1x square nut** into the slot.

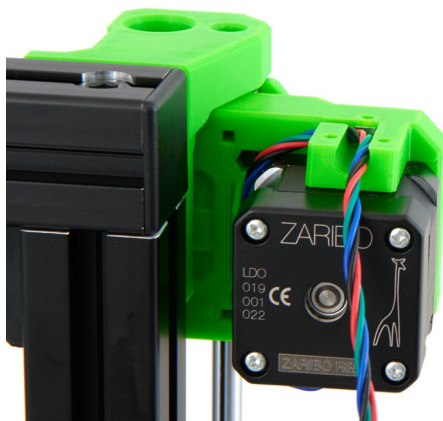

Route the cable over the motor through the plastic part.

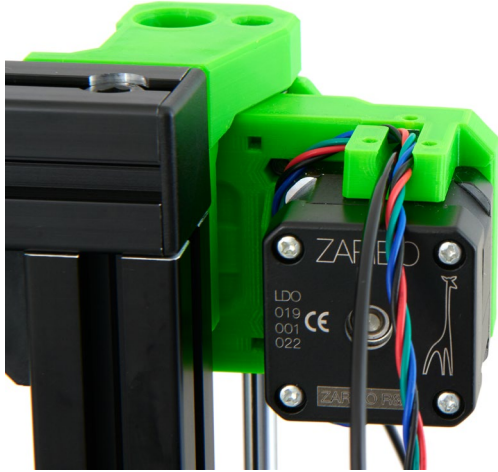

Insert the nylon filament as well into the plastic part.

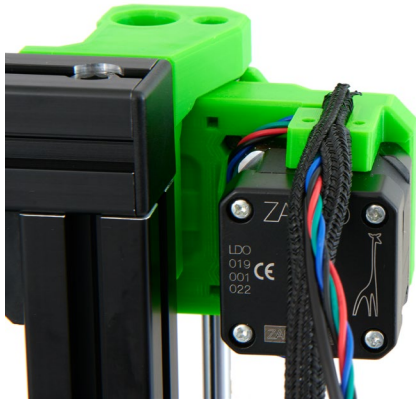

Slide the nylon filament and the cable through the prepared Techflex tube.



Close the holder with the plastic cover



Use **1x M3 x 10mm screw** on the single hole. Use **2x M3 x 14mm screws** on the two holes in the back.,

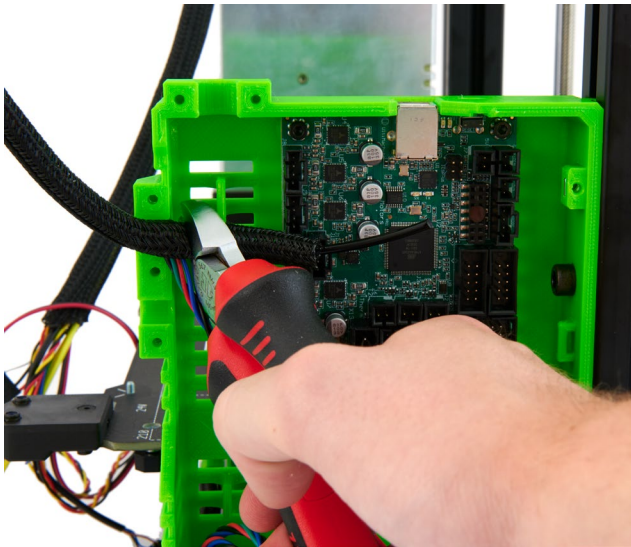

Make sure the cable for the motor to the Einsy goes loosely to the back of the box and cut off additional Techflex tube and nylon filament the goes into the box.

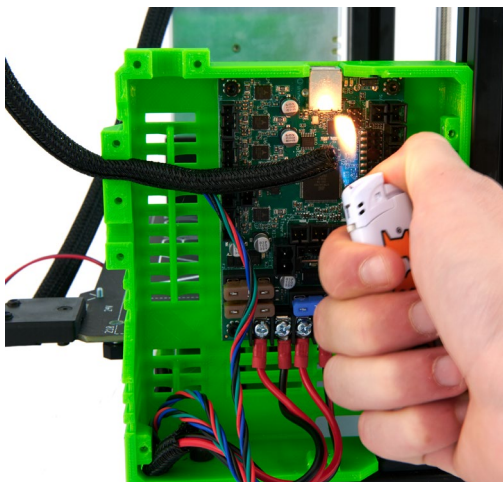

Heat up the end of the Techflex tube with a lighter.

7.2 EXTRUDER CABLES

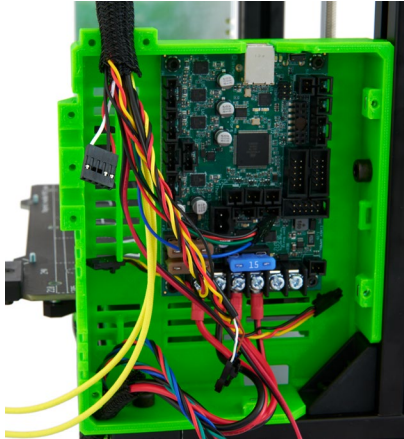

Insert the Techflex tube from the extruder into the top of the Einsky box.

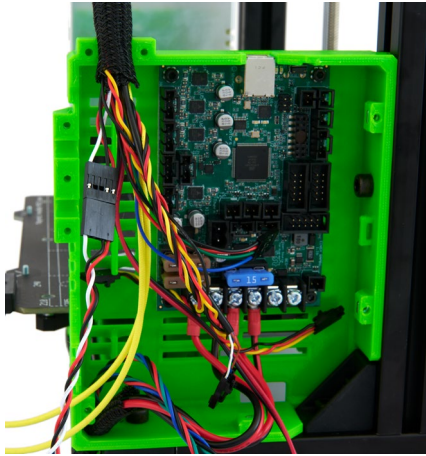

For a Caribou 320 extend the filament sensor cable with one extension cable.

For a Caribou 420 extend the filament sensor cable with two extension cables.

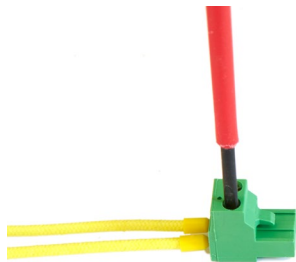

Connect the terminal block to the cable of the extruder cartridge.

(You may also shorten the cable before that. Don't forget to add to crimp new ferrules to the end of the cables).



Plug-in the terminal block.



Route the cable on the left side.



Connect the cable of the extruder thermistor.



Route the cable on the left side.



Plug-in the PINDA cable.

(For Caribou 420 you must extend the cable with a motor extension cable)



Plug-in the extruder motor.

For a Bondtech extruder make sure the black cable is at the top of the connector.



Plug-in the filament sensor cable.

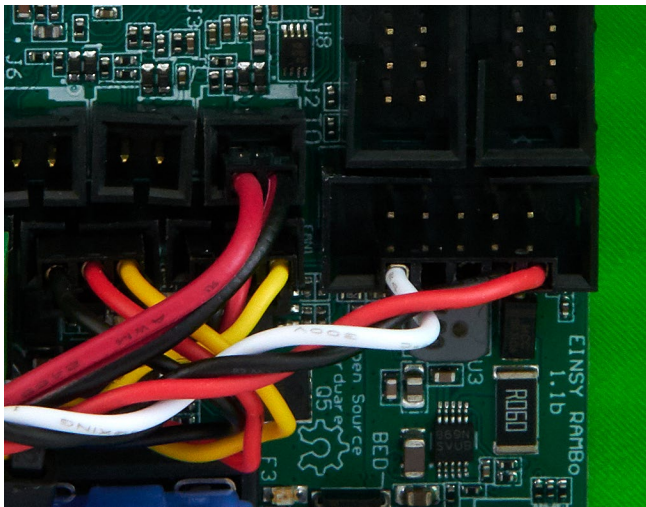

Pay special attention to this connection. Wrong wiring may burn the sensor.



Plug in the y-motor and z-motor cables (cable coming from bottom left into the box).

Plug in the x-motor cable.



Plug in the white cable from the bed thermistor.

(You can shorten this cable as well)



Add some zip ties to make the cable management look a bit nicer.

7.3 LCD CABLE

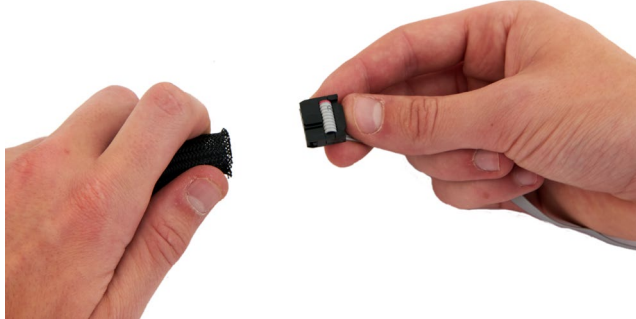

Use the flat cable sleeve to cover the LCD cable.

Heat up both ends first with a lighter.

Lay LCD flat on top of each other and connectors should be in a row, one after the other.

Mark one cable on both sides with "1" and the other with "2".

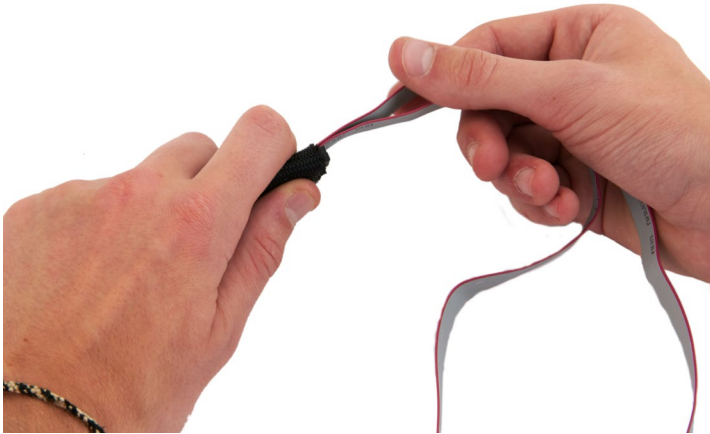

Push the sleeve open and insert the plugs.



Now push the sleeve from one side over the cable and pull it from the other side over the connectors.

(A bit tricky but once you found the right technique it's easy 😊)



Clip two LCD cable clips on the slot on the inside of the left y-extrusion.



Route the LCD cable into the Einsy box.

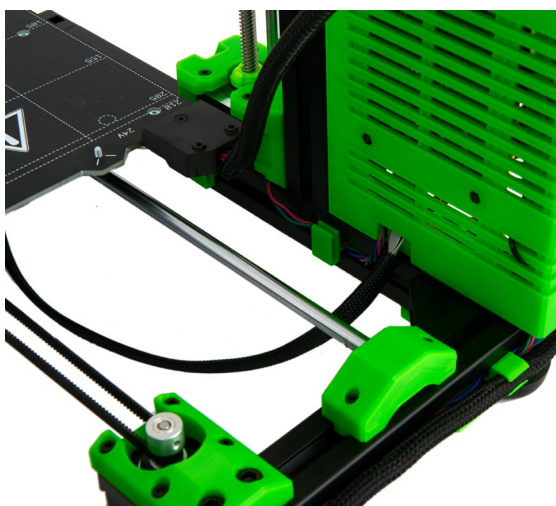

Secure the motor cable with a LCD holder clip.

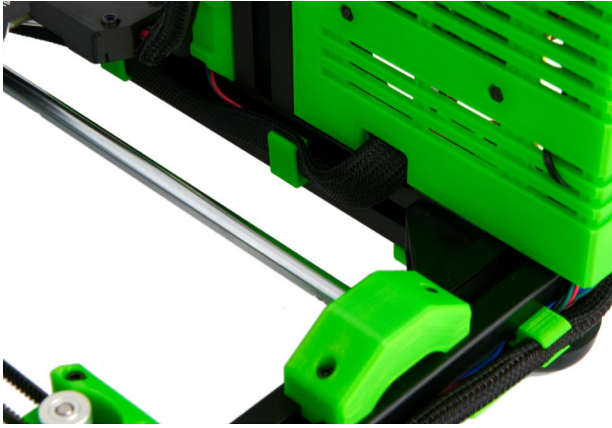

Insert the LCD cable into the LCD holder clip.

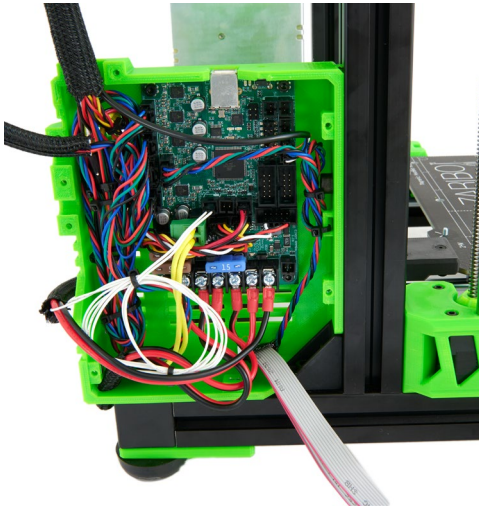

Pull out the LCD cable inside the Einsky box.

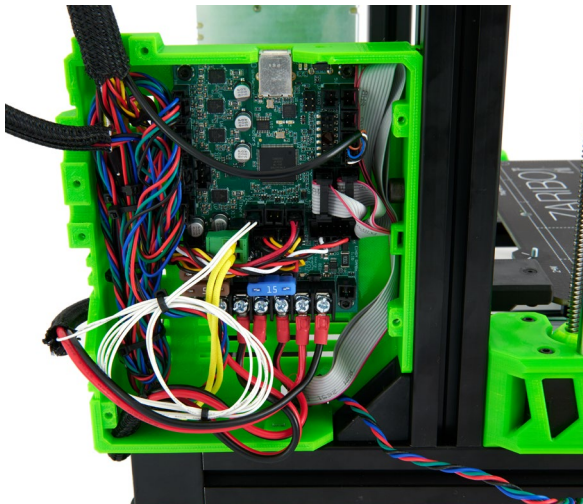

Route the cables in the box and connect to the Einsky board.

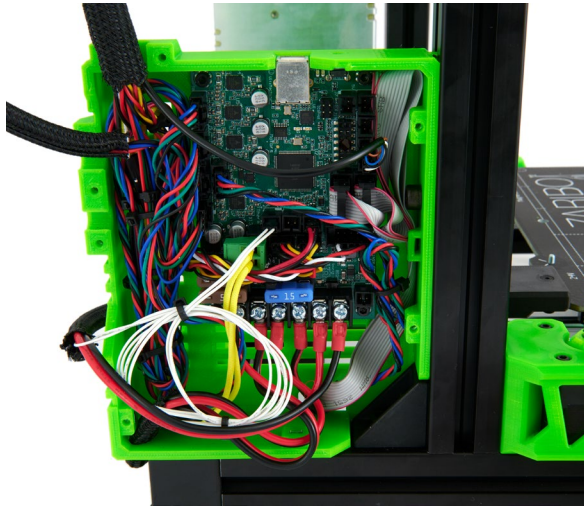

Finally connect the z-motor cable to the board.

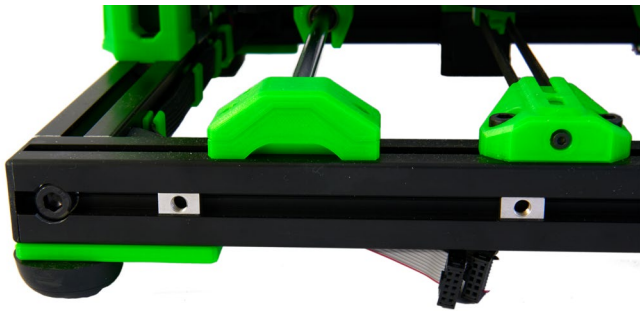

On the front of the printer positions the two T-nuts.

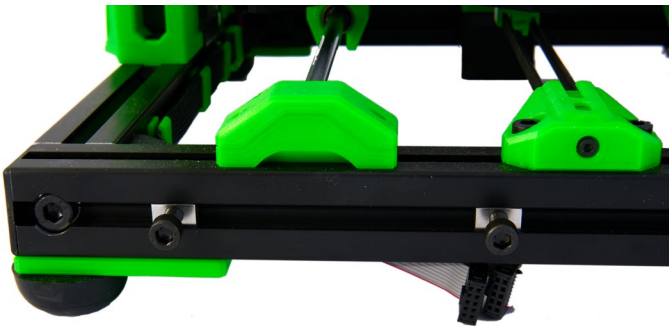

Screw in **2x M6 x 12mm screws** into the T-nuts.



Attach the LCD holder to the slot of the x-extrusion.



Slide in the T-nuts with the screws into the slots on the holder. Fasten gently with a screwdriver.

Do the same with the holder on the right.

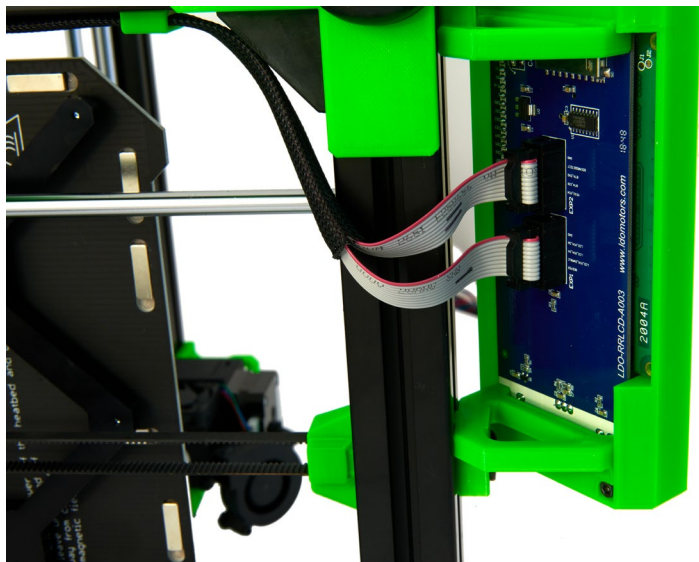

Now connect the LCD cables marked with I and II to the corresponding connectors on the LCD board.

8 STEELSHEET AND HEATBED INSTRUCTIONS

8.1.1 PREPARING THE STEELSHEET



<p>① Buildtak steel sheet</p>	<p>③ Foil squeegee or scraper with microfiber cloth</p>
<p>② PEI sheet</p>	



Remove the sticker from the steel sheet and clean it with IPA.



Remove the sticker from the PEI sheet and remove the protective film on the back on a 2-3cm wide strip.



Align the PEI on one short side of the steel sheet.



Start pressing the PEI sheet against the steel sheet.



Cover the entire surface of the steel sheet, use the scraper in all directions,

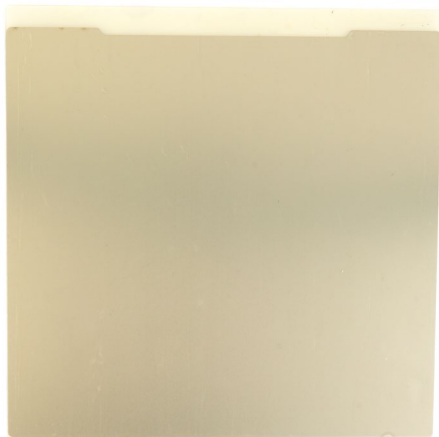

BE EXTRA CAREFUL while working near the edges. **ALWAYS** swipe only out from the sheet, **NEVER** back. You might accidentally lift the PEI sheet up and let some air under it



Trim the extra PEI sheet using a sharp knife.

ALWAYS cut from the side of the applied PEI sheet.



Clean the print surface with IPA.

Done!

8.1.2 **IMPORTANT!** HEATBED INSTRUCTIONS

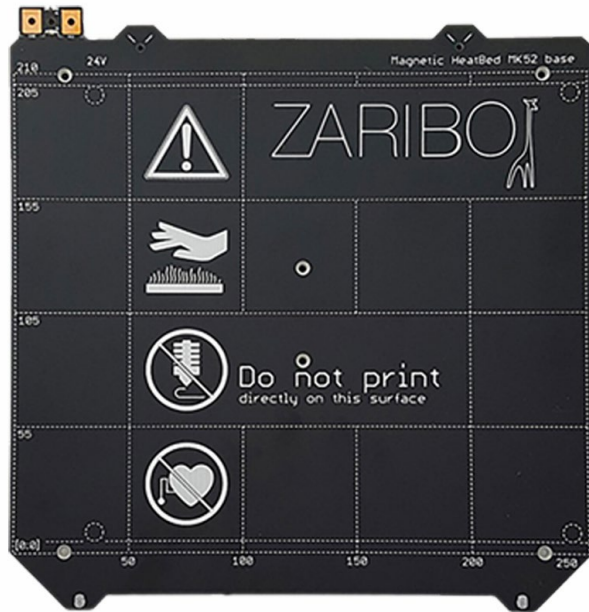

The **MK52** beds are not scratch proof because they are not made to print nor do any other process on them. Magnetic structure of your **MK52** bed lets you magnetically stick a spring steel sheet on it to print on. These spring steel sheets are being manufactured by lots of different vendors. Some of them have fine smooth edges, some have more rough edges, however, regardless of the edge roughness of the steel sheets, **if you stick the steel sheet on the magnetic heated bed and slide it back and forth you will end up with a scraped surface which might reveal the thin copper wiring beneath.**

IMPORTANT: There are two pivot pins on the top surface of your MK52 heat bed and a coherent top notch on your spring steel sheet. Please align the notch(es) of the steel sheet with the pins in question and slowly put down the steel sheet on the heated bed. And do the opposite when your print job finishes.

Try not to slide your steel sheet over the surface of the heated bed.

As mentioned above, due to continuous misuse, copper wiring beneath might reveal in time. If this had happened to you, try applying a thin layer of nail polish to cover the revealed part or simply use a capton tape for the same purpose.

9 SETUP AND CALIBRATION



①	Buildtak steel sheet with PEI sheet	⑧	M6 x 12mm screw
②	PLA filament	⑨	M3 x 18mm screw
③	Silicone sock	⑩	M3 hex nut
④	Fan shroud	⑪	Spoolholder
⑤	M3 x 10mm screw	⑫	Spoolholder cap
⑥	SD card	⑬	Power cord
⑦	USB cable		

9.1 FLASHING FIRMWARE



Before you connect the printer to power make sure that power settings on the PSU are correct.

Plug in the power cord and turn on the printer.



You will see the boot loader. The fans should be running at full speed

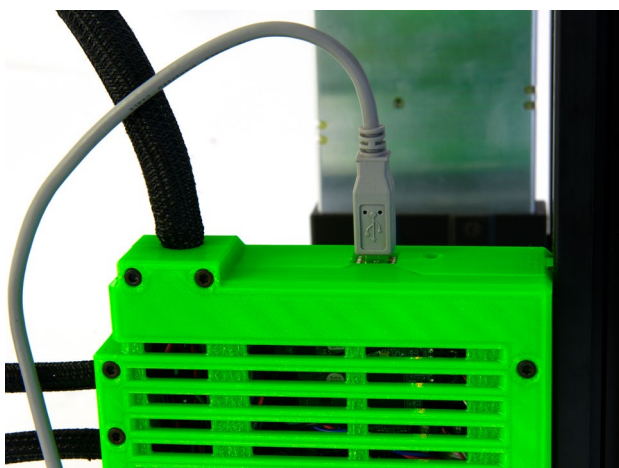

Plug the included USB cable into the 3D-printer and connect it to a PC.



Download and install the program "Prusa Slicer" from:

<https://www.prusa3d.com/prusaslicer>

Start the program "Prusa Slicer" from your Desktop.

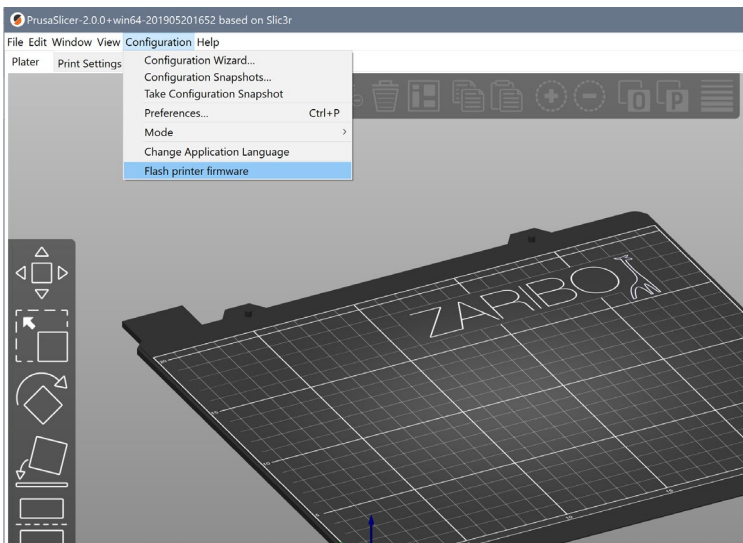

In the "Configuration" tab, select "Flash printer firmware".

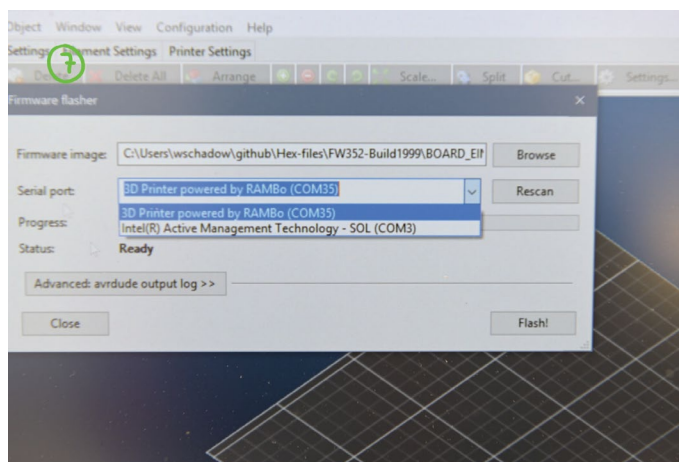

Choose the corresponding Firmware .hex file for height (220/320/420). and extruder

Then Choose the Port with "3D Printer powered by RAMBo"



Press "Flash"

You will see this screen on the printer. Wait for it to complete.



When you installed a multilanguage firmware version you will see this message after the start.

Select the desired language and confirm to update language settings.

In the following we cover only English menu settings.

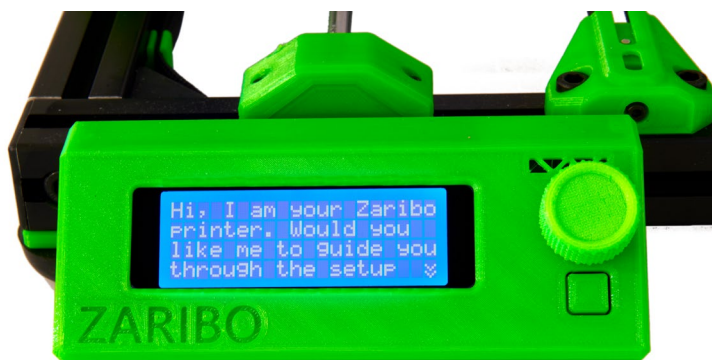

After writing and verifying the printer will boots up, this is what you should see.



Select "No".



You will be taken to the info-screen.

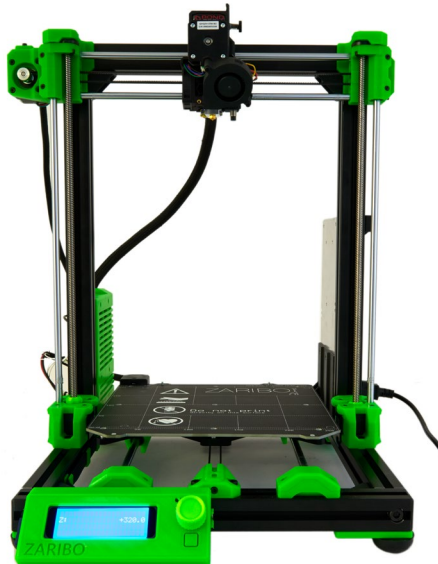

Press and hold the control knob. It is a shortcut to the manual Z-axis control and can be accessed from any menu except when the printer is in operation.

Turn the knob clockwise to move the extruder up. Move it up until it hits the top two brackets, and it will make a relatively loud sound.

This is so that we know the X-axis is level.

9.2 SELF TEST



Click once to exit the z-axis control, and again to enter the main menu. Scroll down and select "Calibration". From there start the "Selftest".



The self-check tests all basic functions of the printer to check if there are any malfunctions or wiring errors.



There is a chance that this message will pop up. Don't lie to the printer! The "left hot end fan" is the extruder fan.

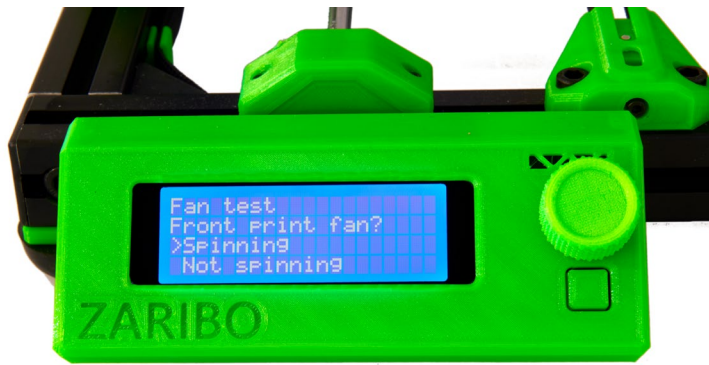

The radial fan in the front is meant here. Check if the fans are spinning or not. Otherwise you may have exchanged the connectors in the Einsy box.



The firmware checks the length of the x- and y-axis as well as the belt tension.

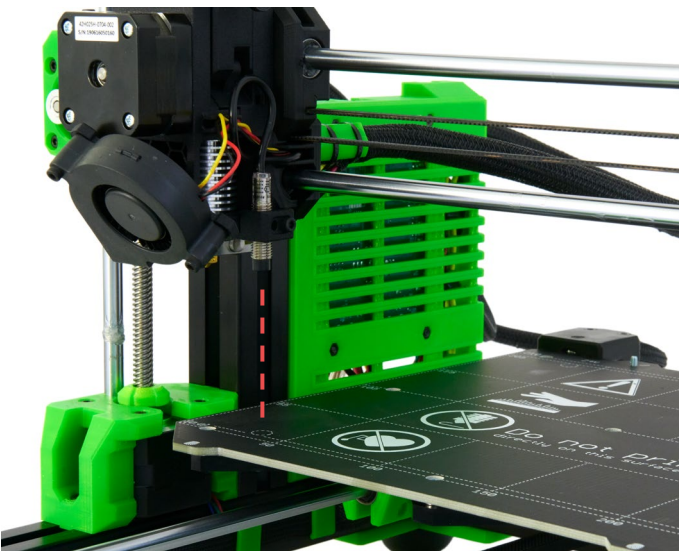

In the self-check process the printer will move the extruder down until the PINDA sensor triggers in presence of the heat bed. Make sure that the PINDA is above the dotted circle marked on the heat bed.

If it is severely misaligned, the sensor might not trigger causing the extruder to go into the heat bed, causing damage.

Should this be the case you will have to check all the parts involved to see if you have properly assembled them.

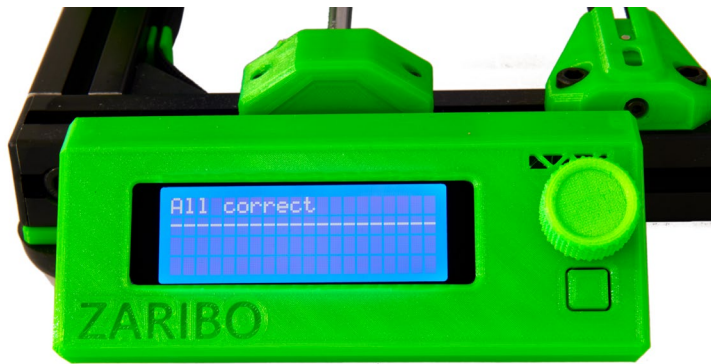

This is (hopefully) what you will see. If not, troubleshoot the described error.



After the self-test the printer will return to the main menu. Before turning off the printer make sure everything has cool down.

9.3 PINDA ADJUSTMENT

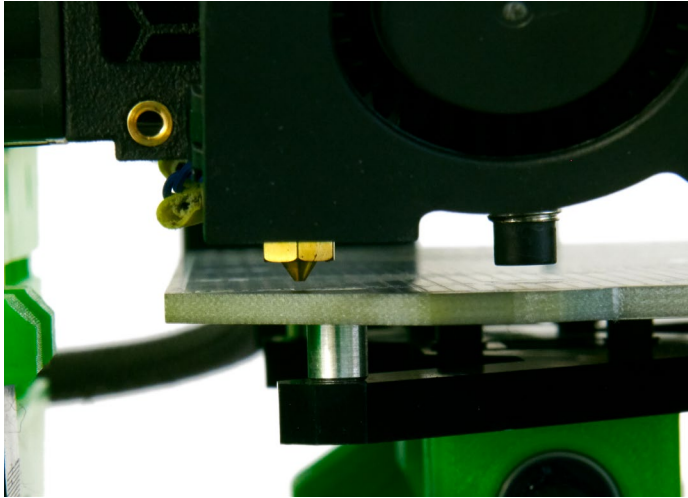

Turn off the printer.

Loosen the PINDA clamp and push the PINDA sensor up by about 5mm. By hand, turn the z-motor- screws counterclockwise at an even rate so that the nozzle nudges the heat bed.

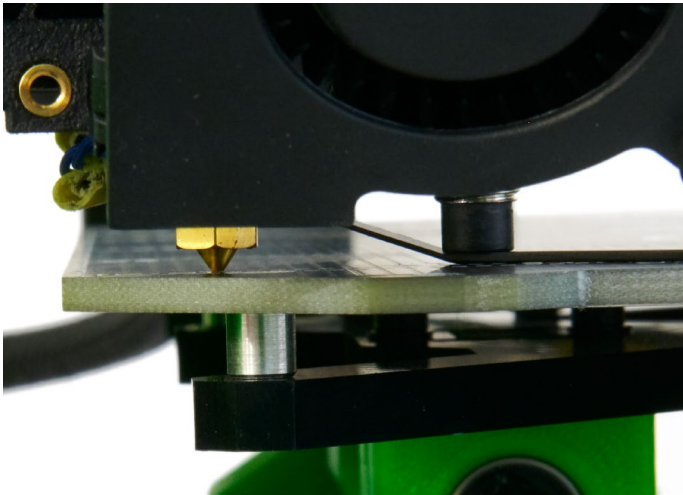

Set the distance between the PINDA and the heat bed to about 0.6mm.

(Although we recommend using a thickness gauge, you can also use the thinner pointy part of the zip ties we include in our kits, which is also 0.6mm thick.)



Turn the printer on again. Press the knob once and scroll down to “settings”

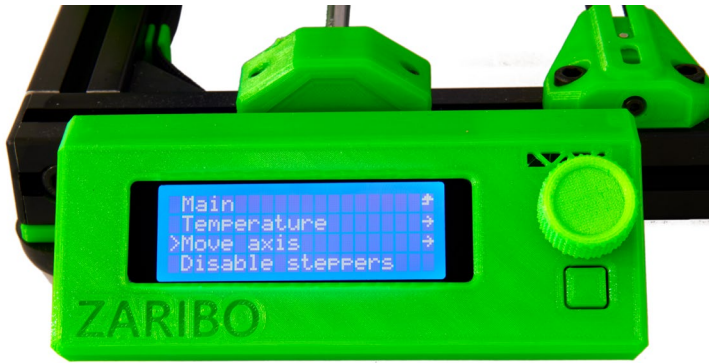

Select "move axis"



First move the z-axis all the way up. When the axis reaches the top, it will make a cracking noise which is normal. Make that **BOTH** sides of the x-axis have reached to top. If not turn printer off and go to this step again.

This step is very important. It ensures that the x-axis is parallel to the bed.

The number in the display is not important now.



Next move the x-axis to the middle of the axis. This give us some workspace for the next step.

9.4 NOZZLE AND HOTEND PREPARATION

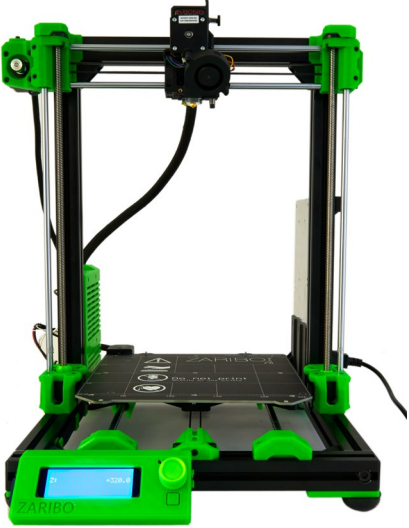
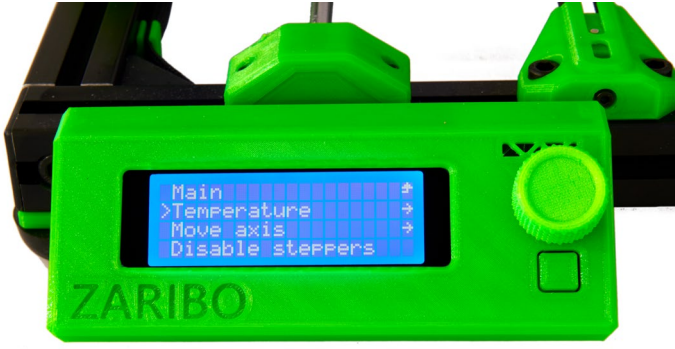
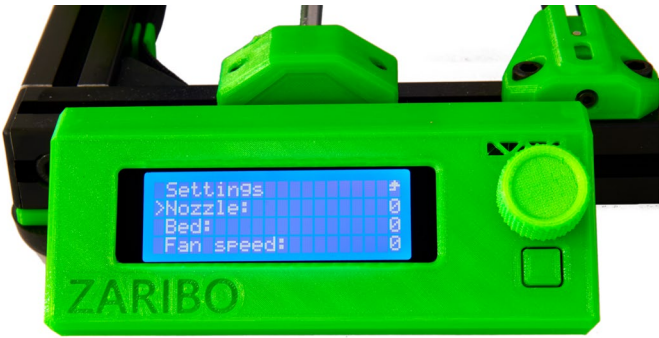
	<p>This will give us more workspace.</p>
	<p>From the main menu, select "Temperature".</p>
	<p>Select "Nozzle"</p>

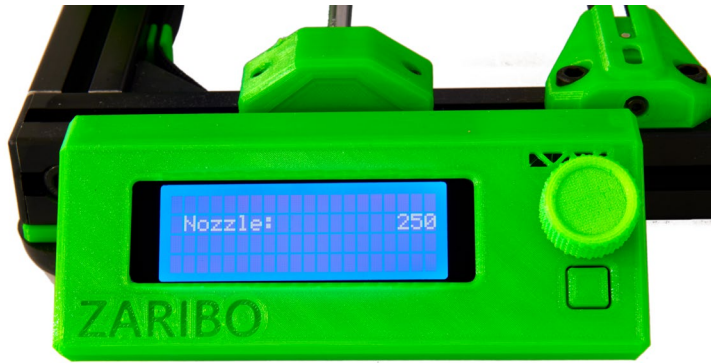

Set the temperature to 250°C. By pressing the knob twice go back to the main menu and till the printer reaches the target temperature.



For the next step, you will need wrenches in the sizes 16mm and 7mm.

As the metal parts expand at high temperatures, we must retighten the nozzle and the nozzle block under similar conditions.

While doing this, also straighten the nozzle block, as we left it slightly angled in the extruder assembly. Be very careful to not turn it clockwise too far!

You will not be able to turn it back. Also be careful as the metal wrenches can get pretty hot.

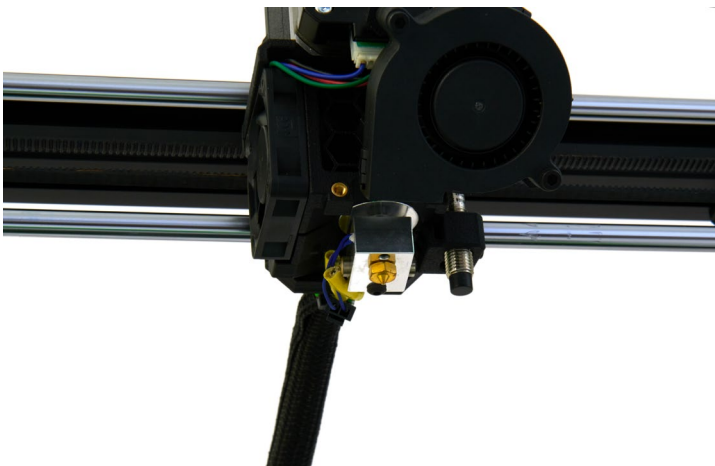

The nozzle and block should now look like this.

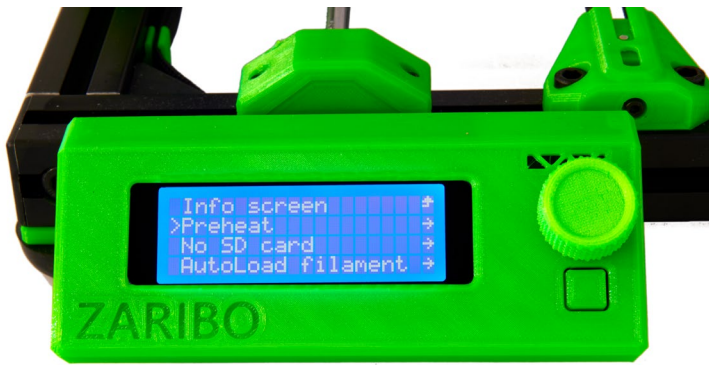

From the main menu press the knob once and go to "Preheat"



Select "Cooldown" and wait until the nozzle temperature is below 50°C.

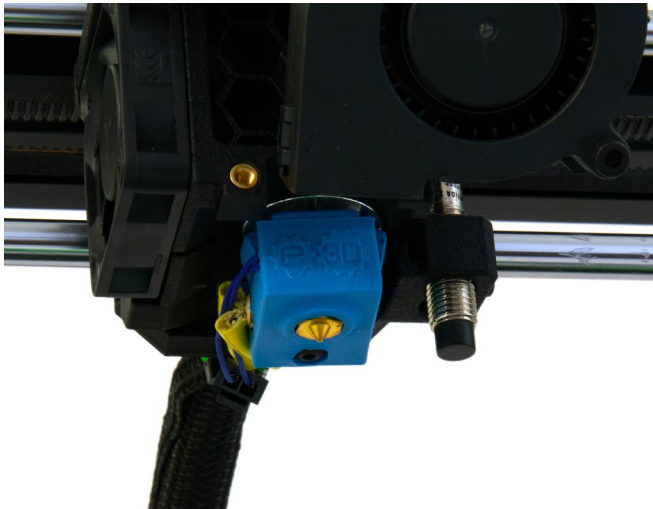

Install the silicone sock.

Make sure the sock is positioned not over the cables, but under them.

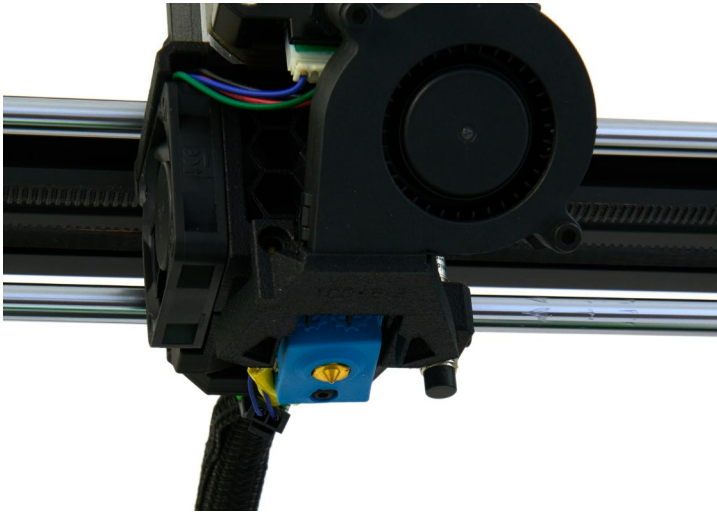

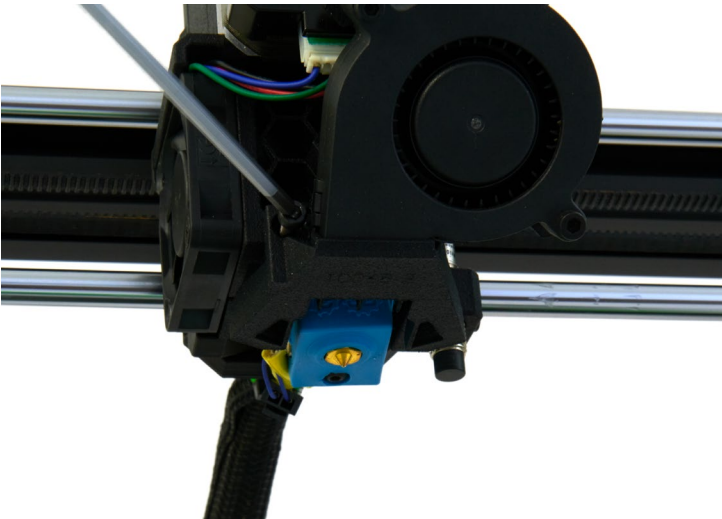

Install the fan shroud. Make sure that the radial fan exhaust is properly seated in the shroud.

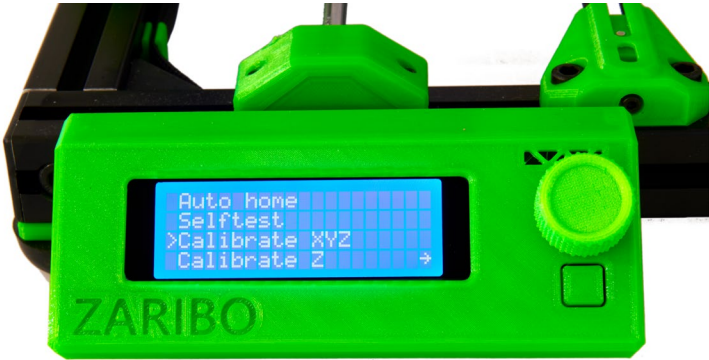

Using an **M3x12mm screw**, fasten the radial fan shroud.

9.5 XYZ-CALIBRATION

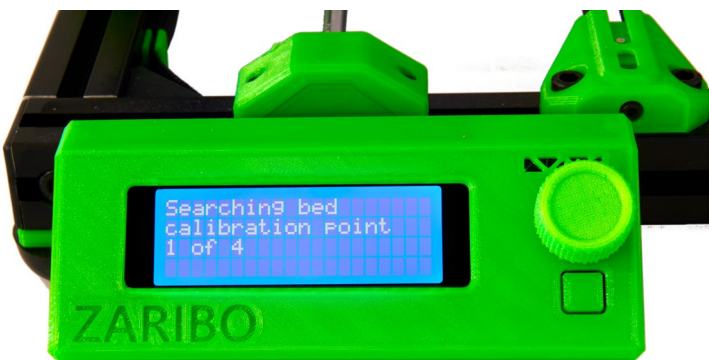
 <p>The image shows the ZARIBO control panel with a blue LCD screen displaying the following menu options:</p> <pre> Auto home Selftest >Calibrate XYZ Calibrate Z </pre>	<p>Navigate to the "Calibration" tab and start the xyz-calibration.</p>
 <p>The image shows the ZARIBO control panel with a blue LCD screen displaying the following question:</p> <pre> Is steel sheet on heatbed? Yes >No </pre>	<p>Make sure that the steel sheet is not on the heat bed and the heat bed is clean. Then select "No".</p> <p>Lay a piece of paper on the heat bed to protect it from the nozzle, should it go too low.</p>
 <p>The image shows the ZARIBO control panel with a blue LCD screen displaying the following status:</p> <pre> Searching bed calibration point 1 of 4 </pre>	<p>Wait until the printer has found all calibration points.</p> <p>When it is done, remove the paper.</p>

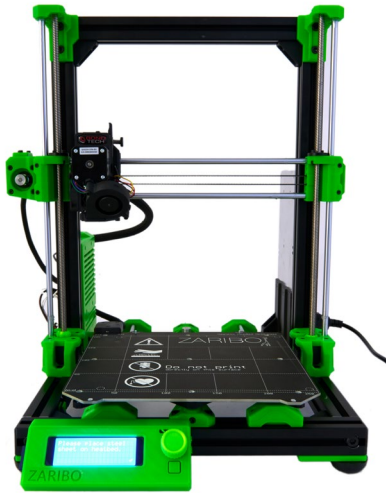

The extruder will rise towards the top, and the printer will prompt you to place the steel sheet on the heat bed.

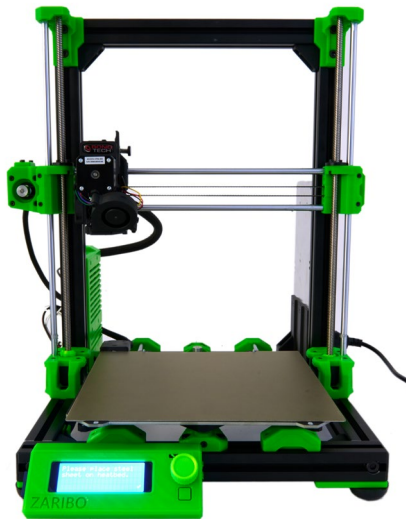

Do this in the orientation shown. Be careful not to scratch up the heat bed.





This is the message you will get if you built the printer well.

You may also receive "slightly skewed but still alright" as a result. In this case the printer can still print well but might not be as good as a printer with the message on the left.

If the calibration fails, revise all steps to check if you have assembled the printer correctly.

9.6 CHECKING THE FILAMENT SENSOR

 <p>The image shows the Zaribo control panel with a monochrome LCD screen. The screen displays a menu with the following items: Calibration, Statistics, Fail stats, and >Support. The 'Support' option is highlighted with a blue bar. The Zaribo logo is visible on the bottom left of the panel.</p>	<p>The self-test only checks the electrical presence of the filament sensor but not if the mechanics is working.</p> <p>From the menu press the knob once and then scroll down to “support”.</p>
 <p>The image shows the Zaribo control panel with the LCD screen displaying the 'Sensor info' menu. The items listed are: >Sensor info, Belt status, Temperatures, and Voltages. The 'Sensor info' option is highlighted. The Zaribo logo is visible on the bottom left of the panel.</p>	<p>From there scroll down to “sensor info”</p>
 <p>The image shows the Zaribo control panel with the LCD screen displaying the 'Sensor state' screen. The screen shows the following status information: PINDA: 0, FINDER: N/A, and IR: 0. The Zaribo logo is visible on the bottom left of the panel.</p>	<p>In the status info you should see this when no filament is inserted.</p>

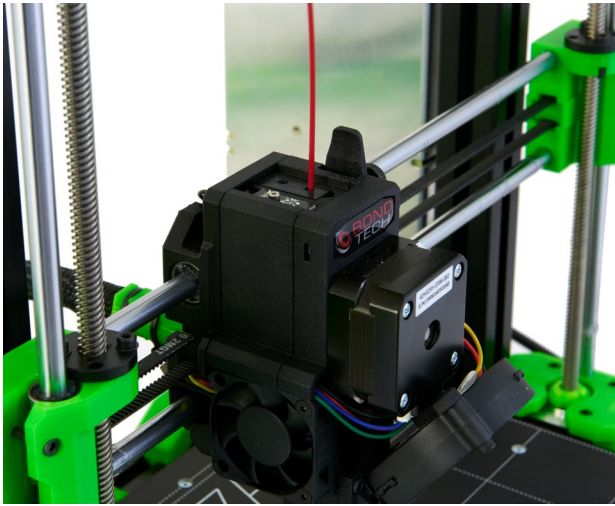

Now insert the filament by about 1 cm.



When filament is inserted the status of the IR sensor should change to "1".

Pull out filament and reinsert a couple of times. Status of the sensor should change accordingly. If not, the lever isn't moving. Lose the screw of the sensor a bit at first.

If that does not help you have to disassemble the extruder body and check for the mechanical problem.

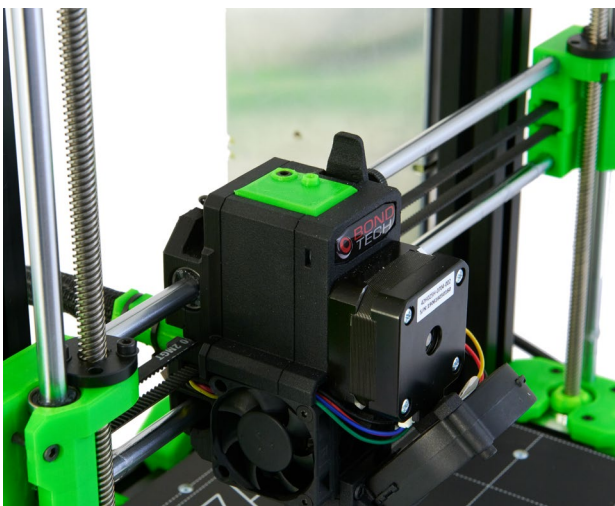

Fasten the filament sensor cover with **1x M3 x10mm screw**

Done!

9.7 LOADING FILAMENT



First, we need to assemble the filament holder.

Use **1x M3 x 18mm screw** to pull in **1x M3 hex nut** into the hole on the inside of the front of the spool holder.



Unscrew the M3 x 18mm screw place and align the spool holder cap and fasten it with the M3 x18mm screw.



The assembled spool holder should look like this.



Using a **1x M6x12mm screw**, install the filament spool holder to the top of the frame.

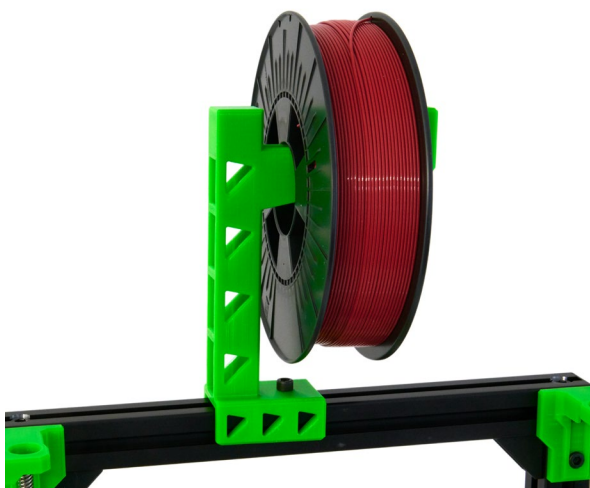

Position the holder with the roller part in the middle.



Place the spool of PLA filament onto the holder so that the filament exits the spool from the back.

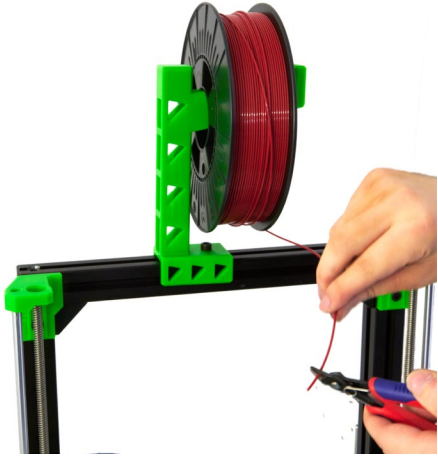

Preheat the printer to the PLA temperature preset.

	<p>Cut the end of the filament at an angle to make it pointy.</p>
	<p>Wait till the printer has reached its target temperature.</p>
	<p>Insert the filament into the top. It will be detected by the filament sensor and the loading of the filament will start automatically.</p>

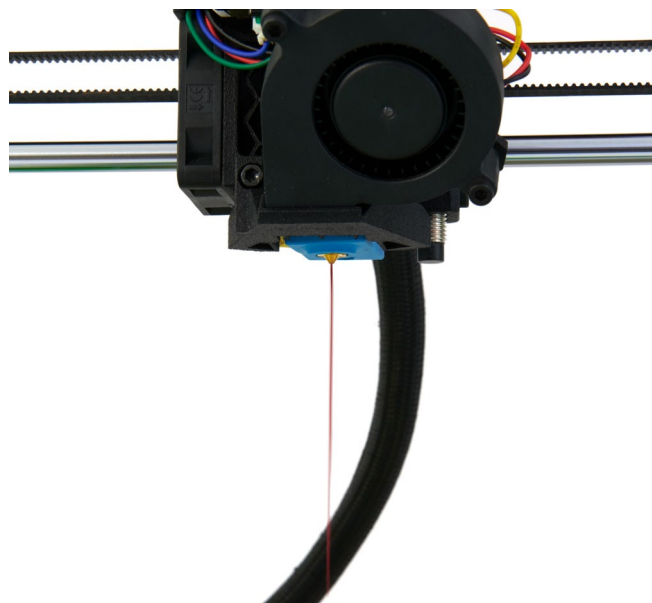

After a few seconds, the filament should come out of the bottom.



Although the filament is the right color, select "No". This is so that we can clear out any fine debris in the nozzle.

The next time select "Yes". Once complete, remove the extruded "spaghetti".

9.8 FIRST LAYER CALIBRATION



In the Calibration tab, select "First layer calibration".

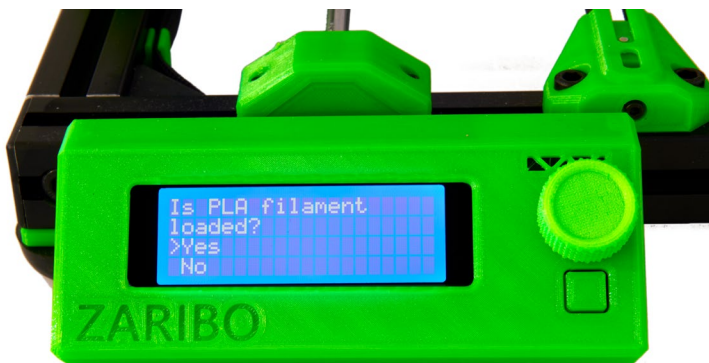

Select "Yes" to start the process.

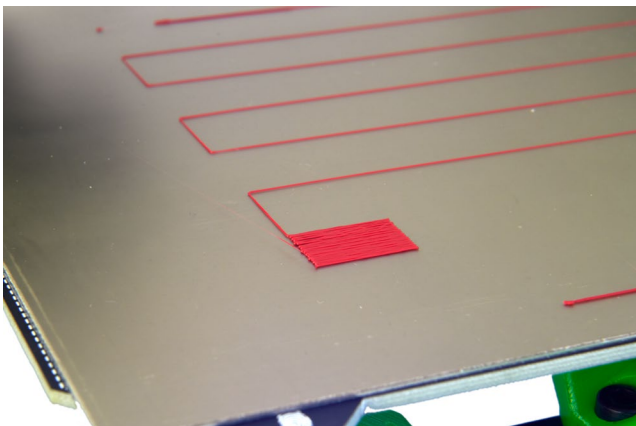

At first the nozzle will be way too high.

Move it down so that the nozzle doesn't print mid-air but also doesn't touch the heat bed.



With the way that we positioned the PINDA sensor, a negative adjustment of about 1mm is as expected.

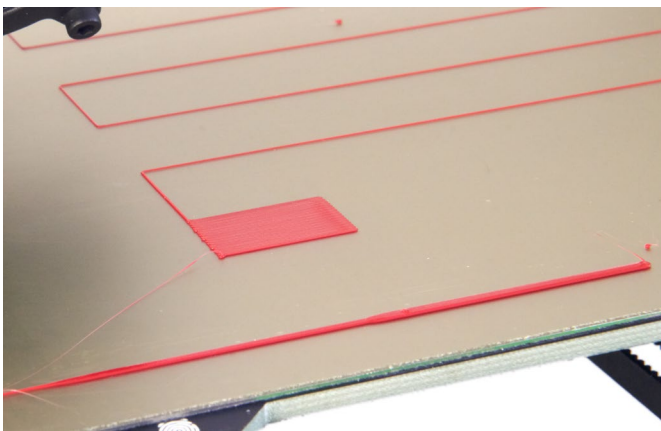

This is what it should look like.



If you think that the height of the heat bed is higher on one side than the other, you may use "Bed level correct" to virtually adjust the sides of the heat bed.



"um" stands for microns.

100 microns = 0.1mm



Once you are satisfied with the Z-calibration, insert the included SD card on the left side of the LCD.

Choose a gcode file to print from.

Note: Double check that the filament can't tangle up on the spool, and also clean the steel sheet with something like alcohol before printing.

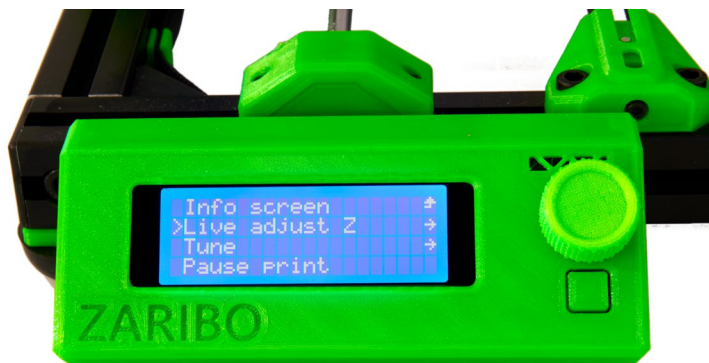

When the print begins, the "Live adjust Z" option will appear. Here you can adjust the height of the first layer again. Any adjustments you make here will be saved for future prints.

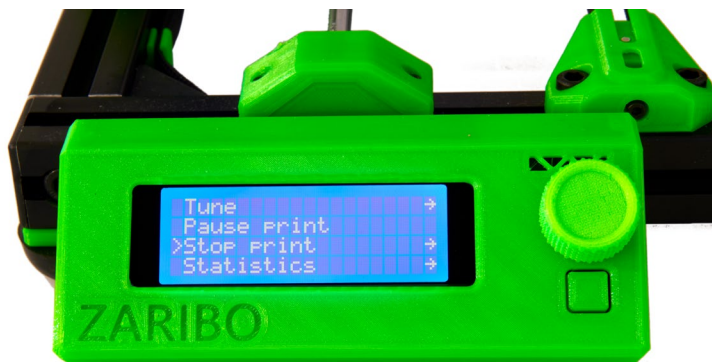

As soon as the printer completes the first layer, stop the print.



As you see, at the start of the print (outside) the z-height was too high. After adjustment it was good (middle).

When the z-height is done, restart the print (after removing all material from the heat bed of course) and let it print till the end.

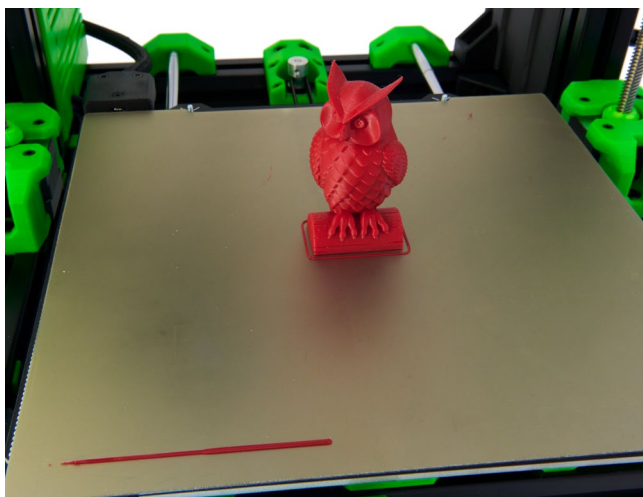

We used this owl as a test print, and it turned out pretty good.

9.9 FINAL STEP: CLOSING THE EINSY BOX

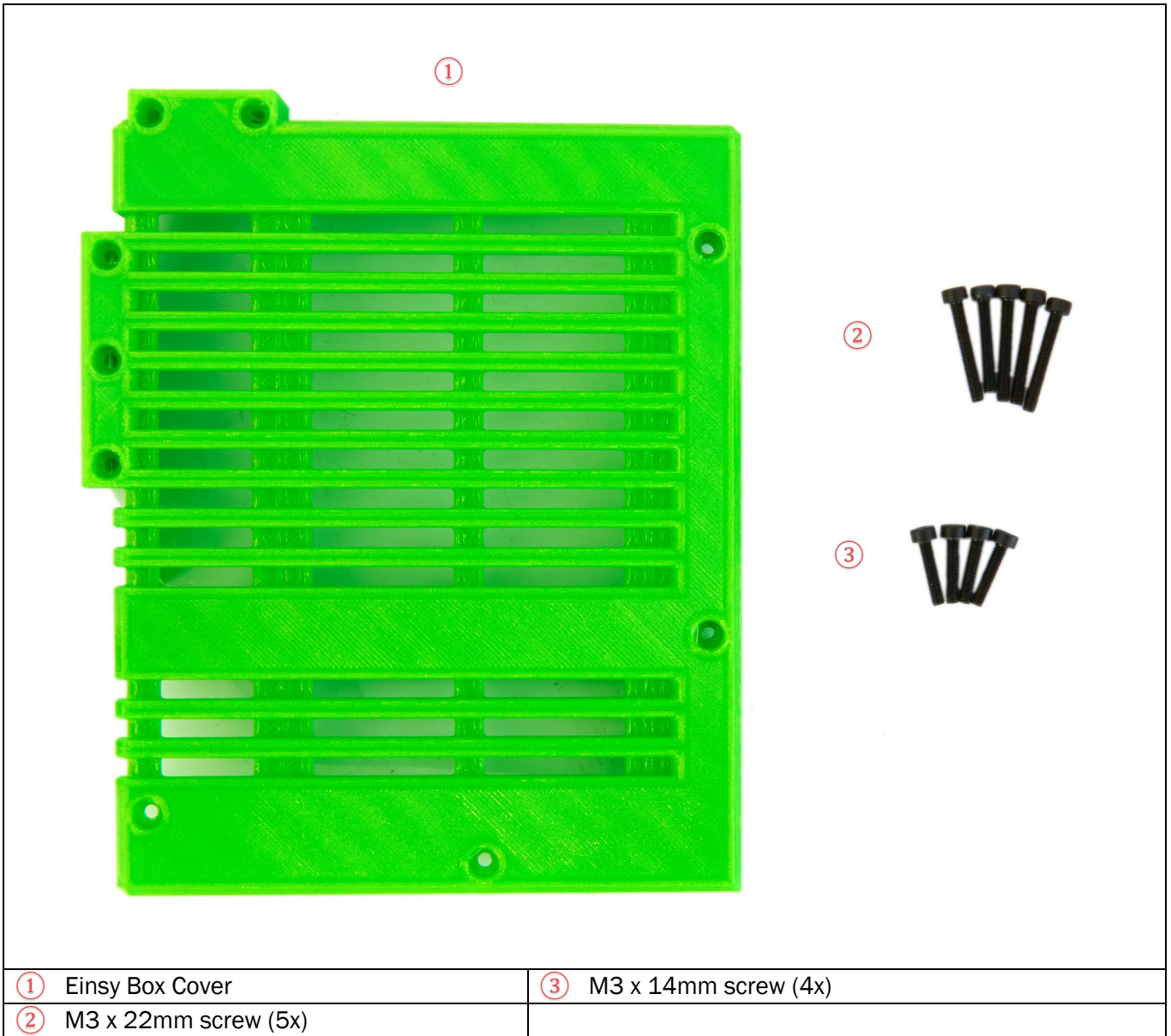



Start with the four M3 x 14mm and screw them into the holes on the right side of the cover.



Screw the M3 x22mm screws into the upper left and upper holes.



Attach the cover to the Einsky Body. Make sure that no cables are in the way. Screw in all screws just a few mm and make sure the cover is in the correct position.



Finally fasten all screws.

Don't overtighten!

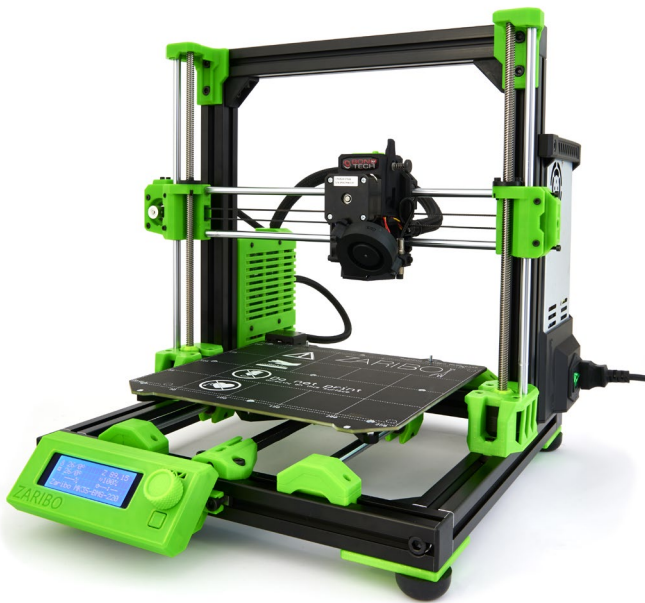

DONE!

Your printer is now complete. Before you continue with your printing adventure, please refer to our operating manual (coming soon)

Happy printing with your new Caribou 😊

A OVERVIEW OF PLASTIC PARTS



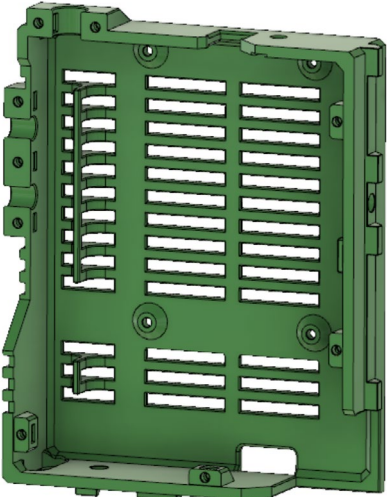
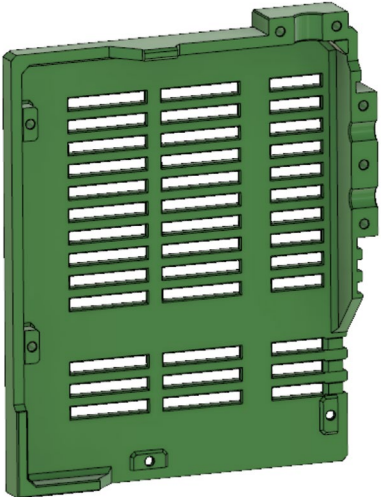

In this chapter we list all plastic parts of the release. On github: <https://github.com/Caribou3d/Caribou-MK3> all STLs files (except Bondtech parts) are available in a corresponding directory structure

A.1 FRAME

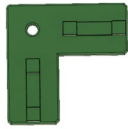

A.1.1 EINSY

	EinsyBox (1x)
	EinsyBoxCover (1x)

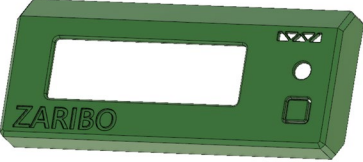

A.1.2 FRAME COMPONENTS

	L-Bracket (4x)
	ExtrusionCableClip (4x)
	LCD Cable Clip (3x)
	ExtrusionSlotCover (optional)

A.1.3 LCD

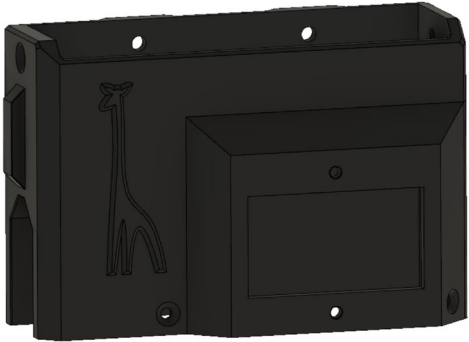

	LCD-Cover (1x)
	LCD-Mount left (1x) LCD-Mount right (1x)
	LCD-Knob (1x)

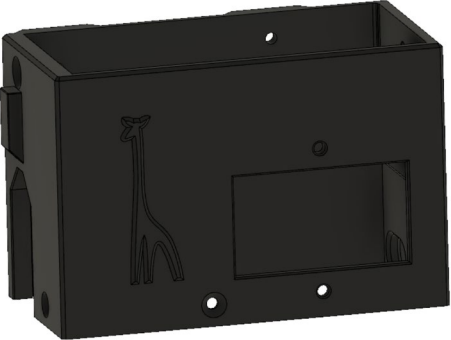
A.1.4 PSU (MEANWELL, PRUSA)

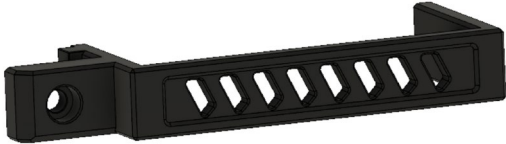
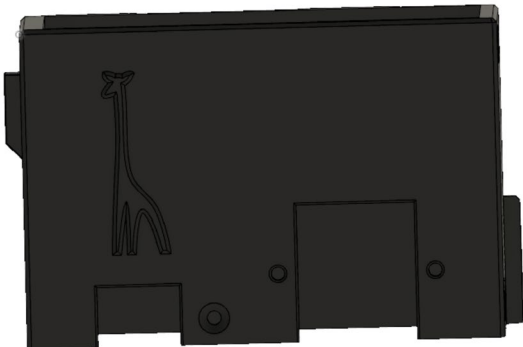
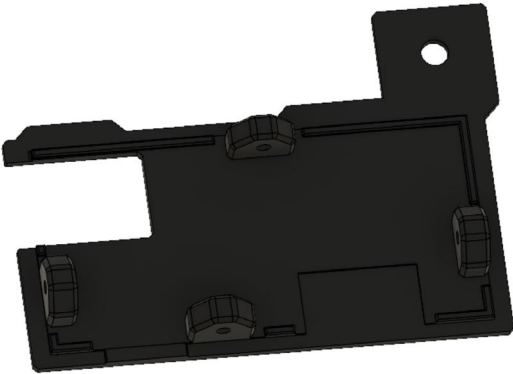
	Meanwell PSU Cover
	Meanwell PSU Cover Bottom
	Meanwell PSU TopMount
	PSU-Cover (OneHole)

 A black plastic component, likely a PSU cover bottom for a one-hole configuration. It features a rectangular shape with a notch on the left side, a circular hole on the right side, and several mounting points and slots.	PSU Cover Bottom (OneHole)
 A black plastic component, likely a PSU top mount. It has a long, narrow profile with a circular hole on the left end and a series of slanted ventilation slots along the top edge.	PSU TopMount (for OneHole and TwoHole)
 A black plastic component, likely a PSU cover for a two-hole configuration. It is a rectangular plate with a giraffe-shaped cutout on the left side, a circular hole on the right side, and a rectangular slot at the bottom.	PSU-Cover (TwoHole)
 A black plastic component, likely a PSU cover bottom for a two-hole configuration. It is a rectangular plate with a circular hole on the right side, a notch on the left side, and several mounting points and slots.	PSU Cover Bottom (TwoHole)

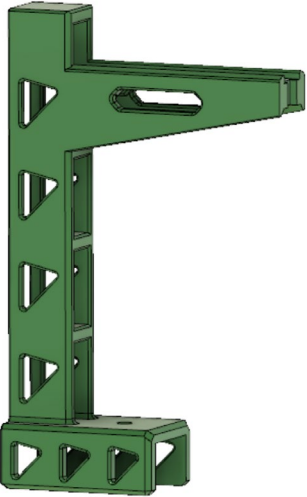

A.1.5 SPOOLHOLDER

	<p>SpoolholderBody (1x)</p>
	<p>SpoolholderEndCap (1x)</p>

A.2 TOOLS

 A green, L-shaped alignment tool with a vertical leg on the left and a horizontal leg on top. The vertical leg has a 'Y' cutout, and the horizontal leg has a 'Z' cutout. A diagonal support structure connects the two legs.	y-AlignmentTool (1x)
 A green, rectangular alignment tool with a 'Z' cutout on the left side. It has a long horizontal base and a shorter vertical leg on the right side.	z-AlignmentTool (1x)
 A white, cylindrical lubrication injector with a knurled end and a central hole.	Lubelinjector-8mm (1x)
 A green, cylindrical cap for the lubrication injector, featuring a knurled end.	LubelinjectorCap-8mm (1x)

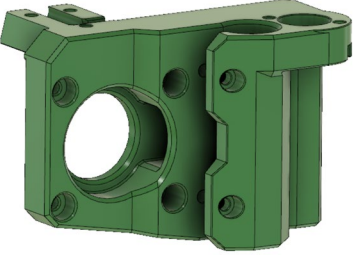
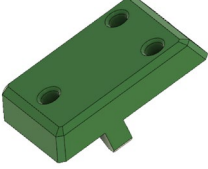
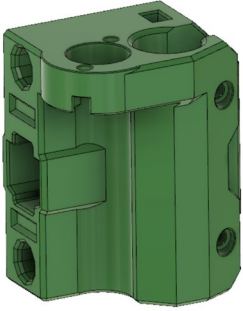
A.3 X-AXIS

	x-MotorHolder (1x)
	x-MotorHolderCover (1x)
	x-Idler (1x)
	xy-BeltTensionerInsert (1x)



A.1.6 BONDTECH SPECIFIC PARTS FOR X-AXIS

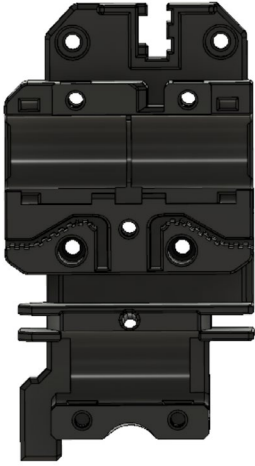
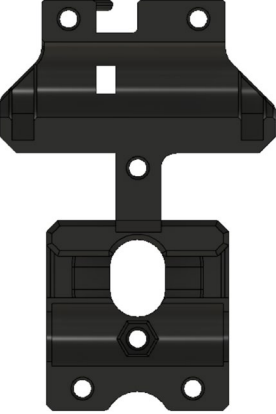
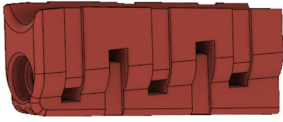

	<p>X-Carriage (1x) (only for Bondtech extruders)</p>
	<p>X-CarriageCoverTop (1x) (only for Bondtech extruders)</p>
	<p>X-CarriageCoverBottom (1x) (only for Bondtech extruders)</p>
	<p>x-CableHolder (1x) (only for Bondtech extruders)</p>

A.1.7 DEFAULT EXTRUDER SPECIFIC PARTS FOR X-AXIS

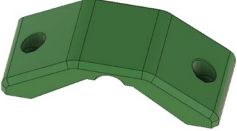

	<p>X-Carriage (1x)</p>
	<p>X-CarriageBack (1x)</p>
	<p>x-CableHolder (1x)</p>

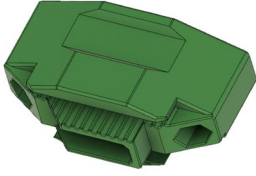
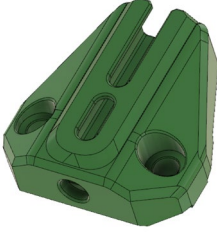
A.4 Y-AXIS

	y-RodHolderBottom (4x)
	y-RodHolderTop (4x)
	y-BearingHolder (1x)
	y-MotorHolder (1x)

	y-BeltHolder (1x)
	y-BeltTensioner (y-Idler) (1x)
	xy-BeltTensionerInsert (1x) (same part as on x-axis)

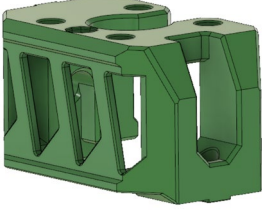
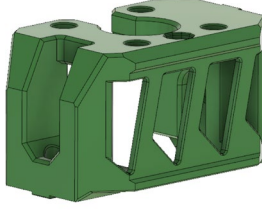
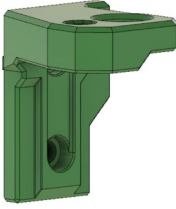

A.5 Z-AXIS

	z-MotorMount left
	z-MotorMount right
	z-TopMount left
	z-TopMount right

A.6 EXTRUDER



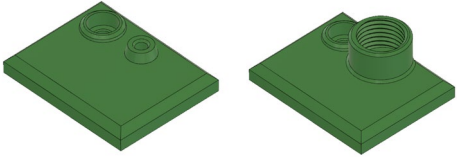
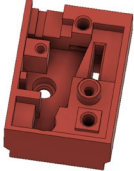

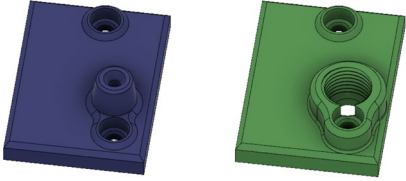
A.1.8 BONDTECH EXTRUDER

	Bondtech extruder body
	Bondtech extruder cove
	Bondtech radial fan holder
	Bondtech fan shroud

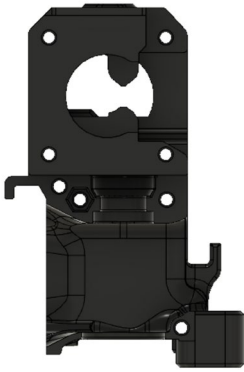
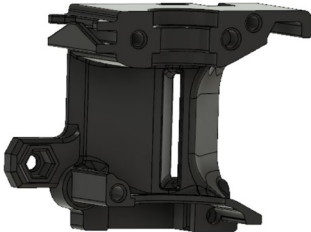
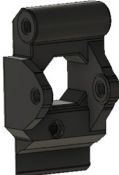
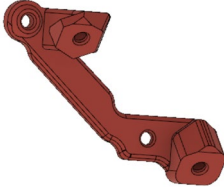
	Bondtech cover / Bowden adapter (MK3s version)
	Filament Sensor housing (MK2.5 / MK3 version)
	Lever
	Filament Sensor Covers (regular and Bowden)

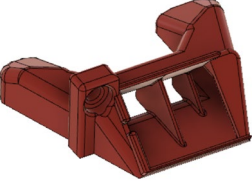
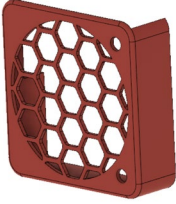
A.1.9 DEFAULT EXTRUDER

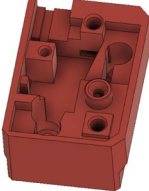
	Extruder Body (1x)
	Extruder Cover (1x)
	Extruder Idler (1x)
	Radial fan holder

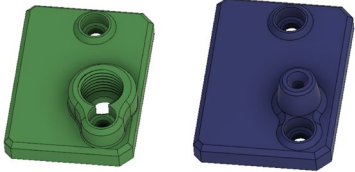
	Fan Shroud
	Noctua cover
	Filament Sensor Cover
	Filament Sensor Housing
	Lever
	Filament Sensor Covers (regular and Bowden)

B LENGTH OF NYLON FILAMENT AND TECHFLEX TUBES

Axis	Type	Caribou		
		220	320	420
		220	320	420
x-Axis	Nylon	37 cm	47 cm	57 cm
	6.4mm Techflex Tube	35 cm	45 cm	55 cm
Heatbed	Nylon	34 cm	34 cm	34 cm
	6.4mm Techflex Tube	32 cm	32 cm	32 cm
Extruder	Nylon	47 cm	57 cm	67 cm
	12.7mm Techflex Tube	45 cm	55 cm	65 cm
PSU	6.4mm Techflex Tube	40 cm	40 cm	40 cm
LCD	15mm flat tube	45 cm	45 cm	45 cm

C EINSY RAMBO CONNECTORS

